

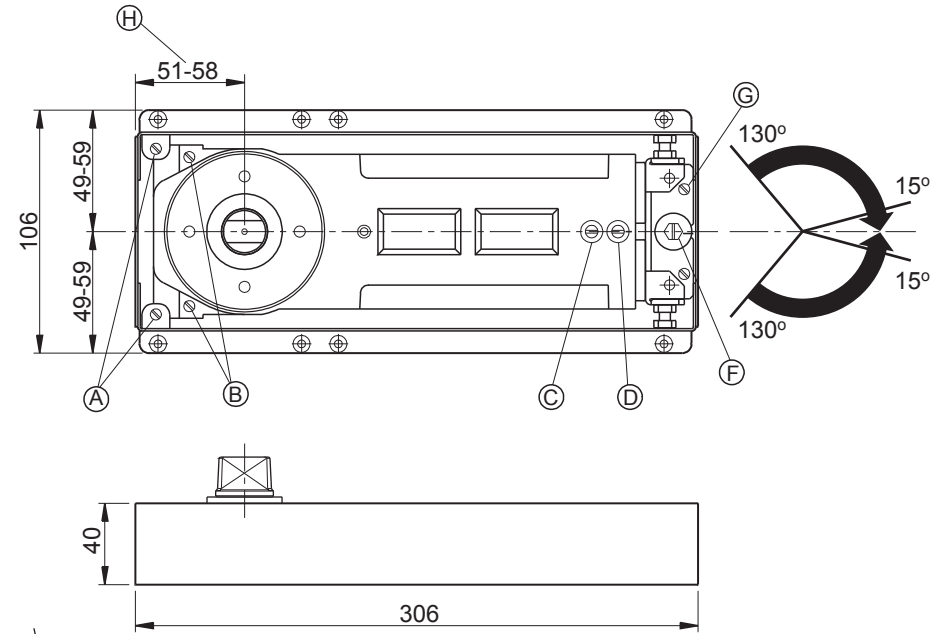

LOCKWOOD 8840 SERIES FLOORSPRINGS
INSTALLATION INSTRUCTION
 ALUMINIUM AND WOOD DOORS ACCESSORIES

Part type (P)	Height (H)
1mm	29mm
3mm	33.5mm
8mm	38.5mm
13mm	43.5mm
18mm	48.5mm
23mm	53.5mm
28mm	58.5mm
33mm	63.5mm

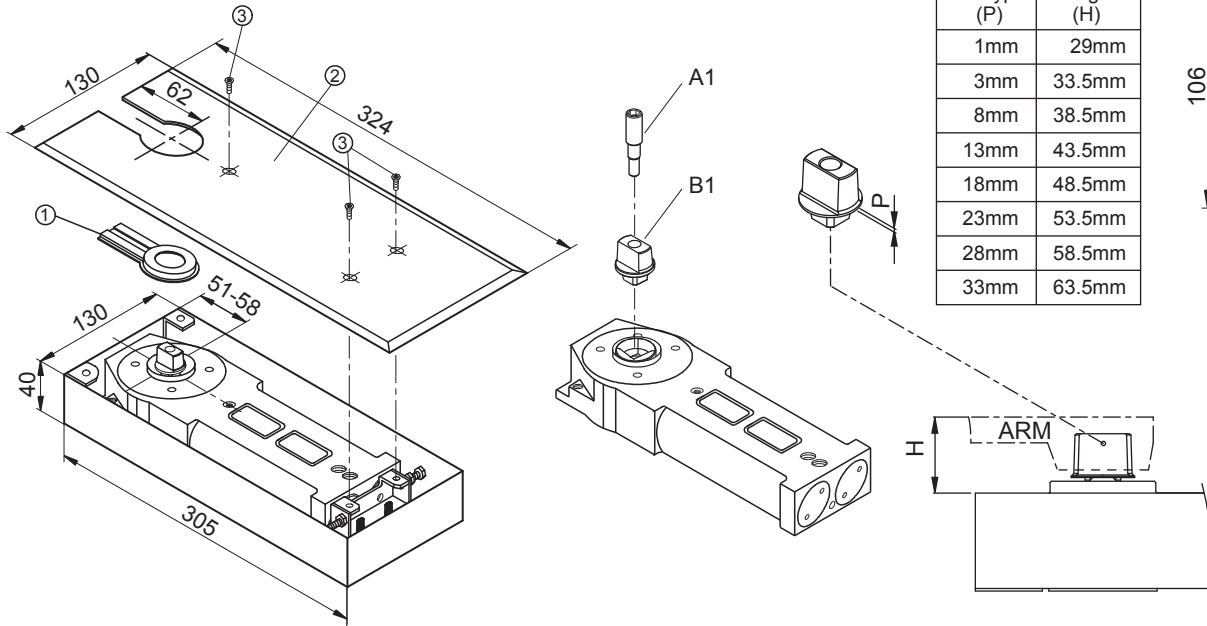

Adjustment in cement box

To adjust the position of floor spring in cement box, (7mm length x 10mm width x 4mm height) loosen fixing screw (A) and (F). Move floor spring to required position and use screw (B) and (G) for height adjustment. Retighten screw (A) and (F) after adjustment.

Centre hung doors

For centre hung doors, floor spring should be in the centre of cement box. Maximum door opening angle is 130° in each direction. For doors opening up to 130° door stop must be fitted. Ensure that top centre is properly aligned with floor spring.

Adjustment of closing speed

Two regulating valve (C) and (D). ☺ decrease closing speed, ☹ increase closing speed.
 Valve C : controlled closing range 130° - 15°
 Valve D : controlled latching range 15° - 0°

Attachment of cover plate

Press insert piece (1) into gap behind spindle.
 Secure cover plate (2) to floor spring with fixing screws (3).

Hold Open

Model H90 will hold door open @ 90° from centre
 Model H105 will hold door open @ 105° from centre

Extended Spindle inserts

Lockwood 8840 series floor springs are fitted with extension spindle inserts to allow for thresholds, carpeted floors or in cases where more clearance between door & floor is required.
 Remove screw (A1) and replace insert (B1) with required height spindle. (Refer spec in catalogue)

Legend

- A = Fixing screw
- B = Height adjustment screw
- C = Regulation valve 130° - 15°
- D = Regulation valve 15° - 0°
- F = Fixing screw
- G = Height adjustment screw
- H = Pivot centre
- 1 = Insert piece
- 2 = Cover plate
- 3 = Fix screw M5x8

Fixing Instruction for double action door

Preparatory work

Mill or route out door frame to accept the relevant top centre parts.

Fixing of top centre frame portion

Put end of pivot beam in hole A, B or C, depending on length of throw required for door type.

- Turn adjustment screw ① until head is screwed right down onto pivot plate.
- Put other end of pivot beam into adjustment screw ① and place on pivot plate, then secure with screw ④.
- Secure cover plate ⑤ to top centre frame portion by using two (2) M4x7.5 screws provided.

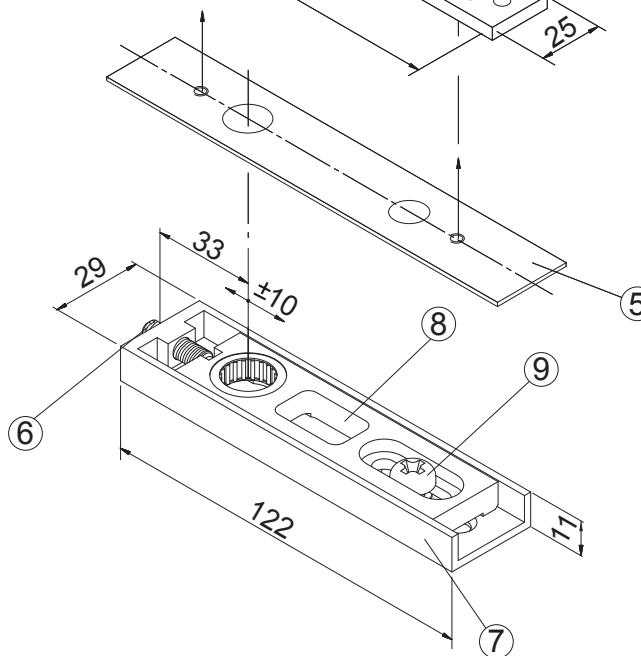
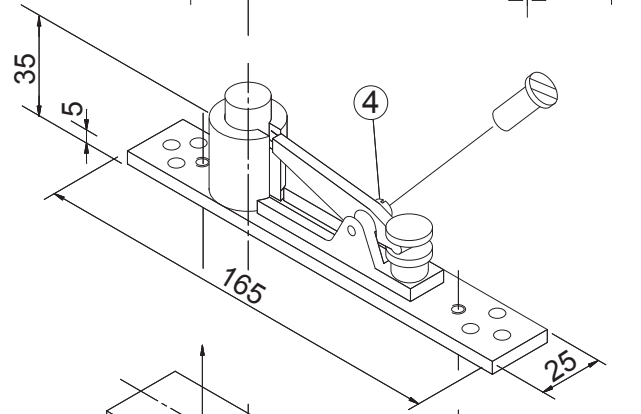
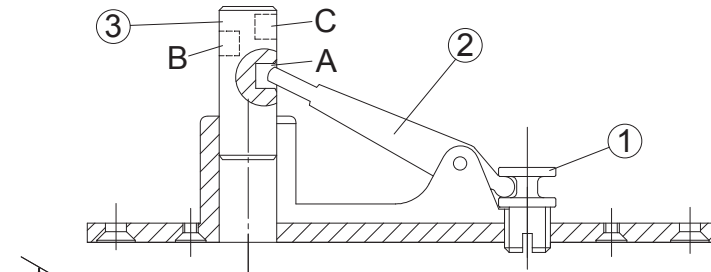

Fixing of top centre door portion

- Insert adjustment screw ⑥ into top centre bar ⑦.
- Insert slide piece ⑧ adjust with screw ⑥ and secure with screw ⑨.

Installation of door

- Offer door leaf onto floor spring and open door slightly.
- Lower pivot into needle bearing in door portion by turning screw ① clockwise.

To raise or lower nose of door, use adjustment screws ⑥ and ⑨. Ensure both are tight before leaving door.

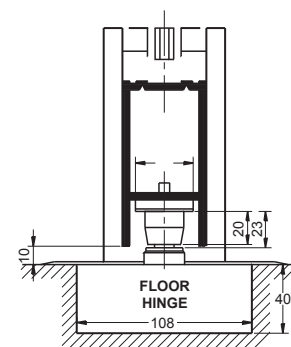
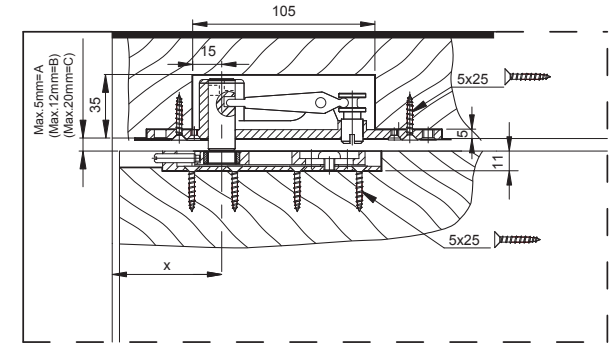
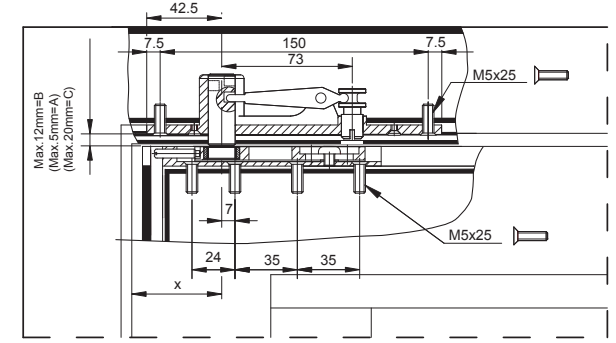
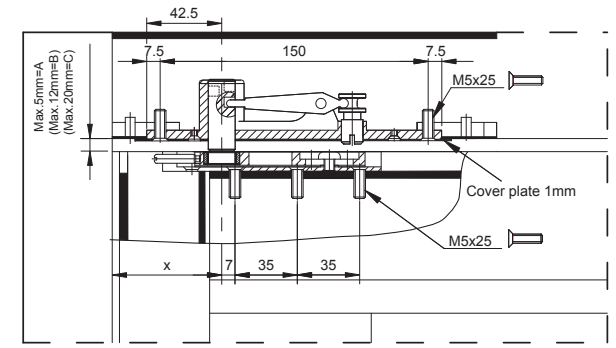
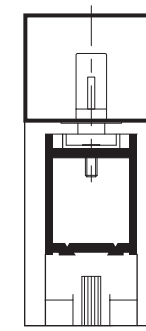

Ensure that top centre is properly aligned with floor spring

