

Synergy Series Mortise Locks Service Manual



We take the worry out of
protecting what's valuable to you.
Lockwood: *no worries*[®]



ASSA ABLOY

www.lockweb.com.au

Introduction



Service Manual:

This manual contains a complete listing of parts and assemblies for the Synergy Series Cylinder Mortice Locks manufactured by ASSA ABLOY Australia. Exploded views are included along with parts list for ordering of replacement components.

ASSA ABLOY Australia reserves the right to make changes in design or specifications, or to make additions or improvements to their product without incurring any obligation to incorporate these amendments in product previously manufactured.

ASSA ABLOY Australia are not responsible for additions or alterations made to their product by others.

Maintenance:

Cleaning: Care should be taken during construction/ refurbishment to ensure that paint, thinners, mortar or cement splashes are carefully removed from locks, furniture and hardware. Removal of these splashes with strong cleaning agents or scourers should be avoided.

Dirt and grime should be regularly removed with a soft damp cloth. A solution of mild soap and water may be required. During cleaning, care should be taken to prevent cleaning solution from entering the cylinder keyway. Surfaces should be dried and possibly lubricated.

Lubrication: During assembly of the lock, the areas of contact of the internal mechanism which require lubrication are given an application of high quality grease. As such further lubrication should not be necessary.

However, where locks are subjected to heavy traffic, the external contact areas of the bolt and strike may require an occasional smear of light machine oil.

Contents

3570 Series Function Matrix	4
3570 Series Nightlatches	6
3571 Series Deadlocks	7
3572/3574 Series Multi-Function Lock	8
3572/3574 Multi-Function Lock Functions	9
3573 Series Sliding Door Deadlocks	10
3577 Series Dual Entry Lock	12
3578 Series Holdback Lock	13
3579 Series SCEC Secure Area Mortice Locks	14
3572AF Series Multi-Functions Locks - Aluminium Fix Lock	15
4570 Series 89mm Extended Backset Mortice Locks	16
5570 Series 127mm Extended Backset Mortice Locks	17
Cylinders	18
Accessories	22
Adaptors	24
3572 Series Mortice Lock - Mounting Instructions	26
3570 Series Mortice Lock - Mounting Instructions	28
3570AF Series Mortice Lock - Installation Instructions	29
3570 Series Mortice Lock - Installation Instructions	30
3571/3573 Mortice Lock - Mounting Instructions	31
3577 Series Dual Entry Mortice Lock - Mounting Instructions	34
3578 Series Mortice Lock - Mounting Instructions	36
3579 Series Mortice Lock - Mounting Instructions	39
3570 Series Rebate Mortice Locks - Mounting Instructions	42

3570 Series Function Matrix

Synergy Series	Function Description	Primary Lock	Cylinder(s)	Turn Adaptor	Outside Cylinder Cam	Inside Cylinder Cam
3570SC	<i>Nightlatch Primary Lock</i>	3570SC	-	-		
3570-T#SC	Nightlatch - turn only	3570SC	-	SP3570-5050		
3570X-#SC	Nightlatch - single cyl	3570SC	570-2SC	-	X	
3570XT#SC	Nightlatch - cyl & turn	3570SC	570-2SC	SP3570-5050	X	
3570XX#SC	Nightlatch - double cyl	3570SC	570-701SC	-	X	X
3571SC	<i>Deadlock Primary Lock</i>	3571SC	-	-		
3571DE#SC	Escape Deadlock	3571DE#SCNCYL	571-2SC	(SP3571-6050)*	Y	
3571-T#SC	Exit Door Deadlock	3571SC	-	SP3571-5050		
3571PT	Privacy Deadlock (Through Fix)	3571PTSC	-	(SP3571-5050)*		
3571WT#SC	Cylinder and Turn Deadlock	3571SC	575-2SC	SP3571-5050	Y	
3571Y-#SC	Single Cylinder Deadlock	3571SC	571-2SC	-	Y	
3571YY#SC	Double Cylinder Deadlock	3571SC	571-701SC	-	Y	Y
3572SC	<i>Multi-function Primary Lock</i>	3572SC	-	-		
3572#SC	Exit Door Latch	3572SC	-	-		
3572EA#SC	Escape Privacy Latch - Anti-lockout	3572SC	-	SP3572-5250		
3572M-#SC	Anti-Vandal Latch	3572SC	575-52SC	SP3572-5350 (RH), SP3572-5450 (LH)	M	
3572-T#SC	Exit Door Lock - turn only	3572SC		SP3572-5250		
3572WA#SC	Escape Office Lock - Anti-lockout	3572SC	575-2SC	SP3572-5250	W	
3572WT#SC	Escape Office Lock	3572SC	575-2SC	SP3572-5250	W	
3572X-#SC	Storeroom Lock	3572SC	570-2SC		X	
3572XA#SC	Entry Door Lock - Anti-vandal	3572XA#SCNCYL	570-302LHSC, 570-302RHSC	(SP3571-6050)*	XAL/XAR	
3572XT#SC	Entry Door Lock	3572SC	570-2SC	SP3572-5250	X	
3572XZ#SC	Double Cylinder Escape Lock	3572SC	574-701SC		X	Z
3572-Z#SC	Single Cylinder Exit Door Lock	3572SC	572-2SC			Z
3572Z-#SC	Classroom Lock	3572SC	572-2SC		Z	
3573SC	<i>Sliding Door Deadlock Primary Lock</i>	3573SC				
3573DE#SC	Sliding Door Escape Deadlock	3573DE#SCNCYL	571-2SC	(SP3571-6050)*	Y	
3573PT#SC	Sliding Door Privacy Lock (Through Fix)	3573PTSC		(SP3571-5050)*		
3573-TSC	Sliding Exit Door Deadlock	3573SC		SP3571-5050		
3573WTSC	Sliding Door Cylinder and Turn Deadlock	3573SC	575-2SC	SP3571-5050	W	
3573Y-#SC	Single Cylinder Sliding Door Deadlock	3573SC	571-2SC		Y	
3573YY#SC	Double Cylinder Sliding Door Deadlock	3573SC	571-701SC		Y	Y
3574SC	<i>Passage Latch</i>	3574SC				
3574#SC	Passage Latch	3574SC				
3574ET#SC	Privacy Latch	3572SC		SP3572-5250		
3574WT#SC	Office Lock	3572SC	575-2SC	SP3572-5250	W	
3574XX#SC	Double Cylinder Override Lock	3572SC	570-701SC		X	X
3574XZ#SC	Glass Entry Door Lock	3572SC	574-701SC		X	Z
3574-Z#SC	Single Cylinder Glass Door Lock	3572SC	572-2SC			Z
3574Z-#SC	Single Cylinder Glass Entry Door Lock	3572SC	572-2SC		Z	
3574ZZ#SC	Double Cylinder Glass Door Lock	3572SC	572-701SC		Z	Z
3577SC	<i>Dual Entry Primary Lock</i>	3577SC~				
3577EA#SC	Key Entry Privacy Lock	3577SC~	3P77/101SC	SP3572-5250		
3577M#	Dual Entry Lock - Key Lockout	3577SC~	575-52SC and 577-2SC	SP3572-5350 (RH), SP3572-5450 (LH)	M	
3577X#	Dual Entry Lock	3577SC~	570-2SC and 577-2SC		X	
3577Z#	Dual Entry Lock - Key Lockout	3577SC~	572-2SC and 577-2SC		Z	
3578SC	<i>Holdback Primary Lock</i>	3578SC				
3578M-#SC	Anti-Vandal Latch - Holdback	3578SC	575-52SC	SP3572-5350 (RH), SP3572-5450 (LH)	M	
3578WT#SC	Escape Office Lock - Holdback	3578SC	575-2SC	SP3572-5250	W	
3578Z-#SC	Classroom Lock - Holdback	3578SC	572-2SC		Z	
3578XZ#SC	Double Cylinder Lock - Holdback	3578SC	574-701SC		X	Z

Items in Italics are Primary locks and can be purchased from ASSA ABLOY

#= Left (L) or Right (R) handing

*= Included with Primary Lock

^= Cam only, included with Primary lock

~= Can be ordered as 3572SC and SP3577-5619. Cylinders must be ordered separately.



ASSA ABLOY

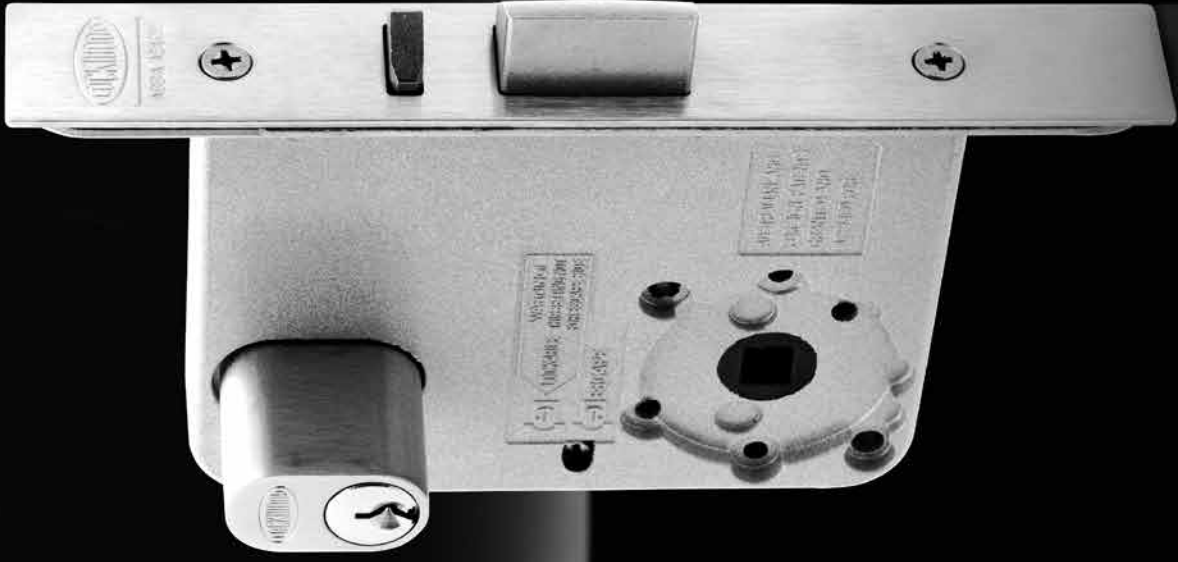

Synergy 3570 Series

3570 Series Nightlatches

Various latching functions operated by a key outside and by a turnknob or key inside. The Nightlatch locks automatically when the door is closed.

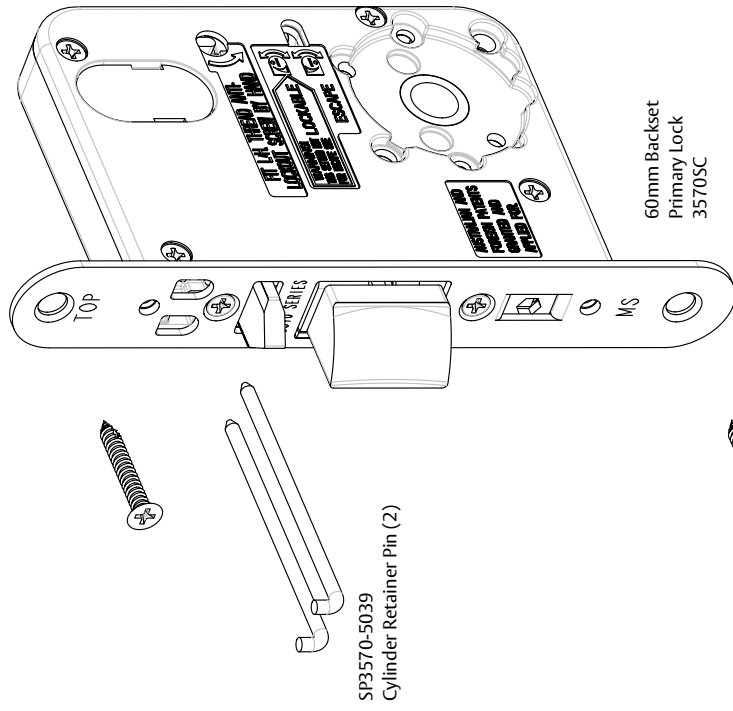

60mm Backet
Primary Lock
3570SC

SP3570-5039
Cylinder Retainer Pin (2)

SP570-130ZP
Mounting Screw (2)

SP3570-5036SSS
SP3570-5136CP/PB
Face Plate

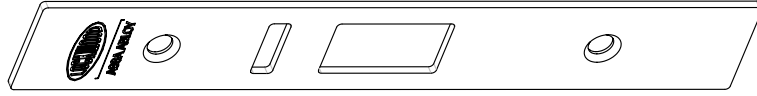

SP3570-5333CP/PB
SP3570-5332SSS
Mounting Plate Screws (2)

SP570-130ZP
SP570-130PB
Mounting Screw (2)

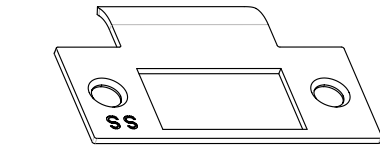

SP500-252ZP
Strike Box

SP3570-5153CP/PB
SP3570-5053SSS
Strike

3570 Series Nightlatch Lock Functions

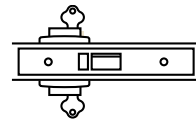

Communicating Door Latch
3570XX

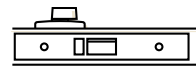

Exit Door Latch
3570-T

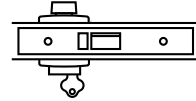

Nightlatch
3570XT

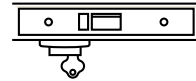

Cylinder Latch
3570X

3570 Series Nightlatch

Orderable Locks

3570SC* Nightlatch Primary Lock

3570TSC Nightlatch Primary Lock with Nightlatch Turn Adaptor

3570AFSC Nightlatch Primary Lock Aluminium Fix

*Also available in Chrome Plate and Polished Brass finishes

3571 Series Deadlocks

These locks have various deadlocking functions which can be operated by key outside and by turnknob or key inside.

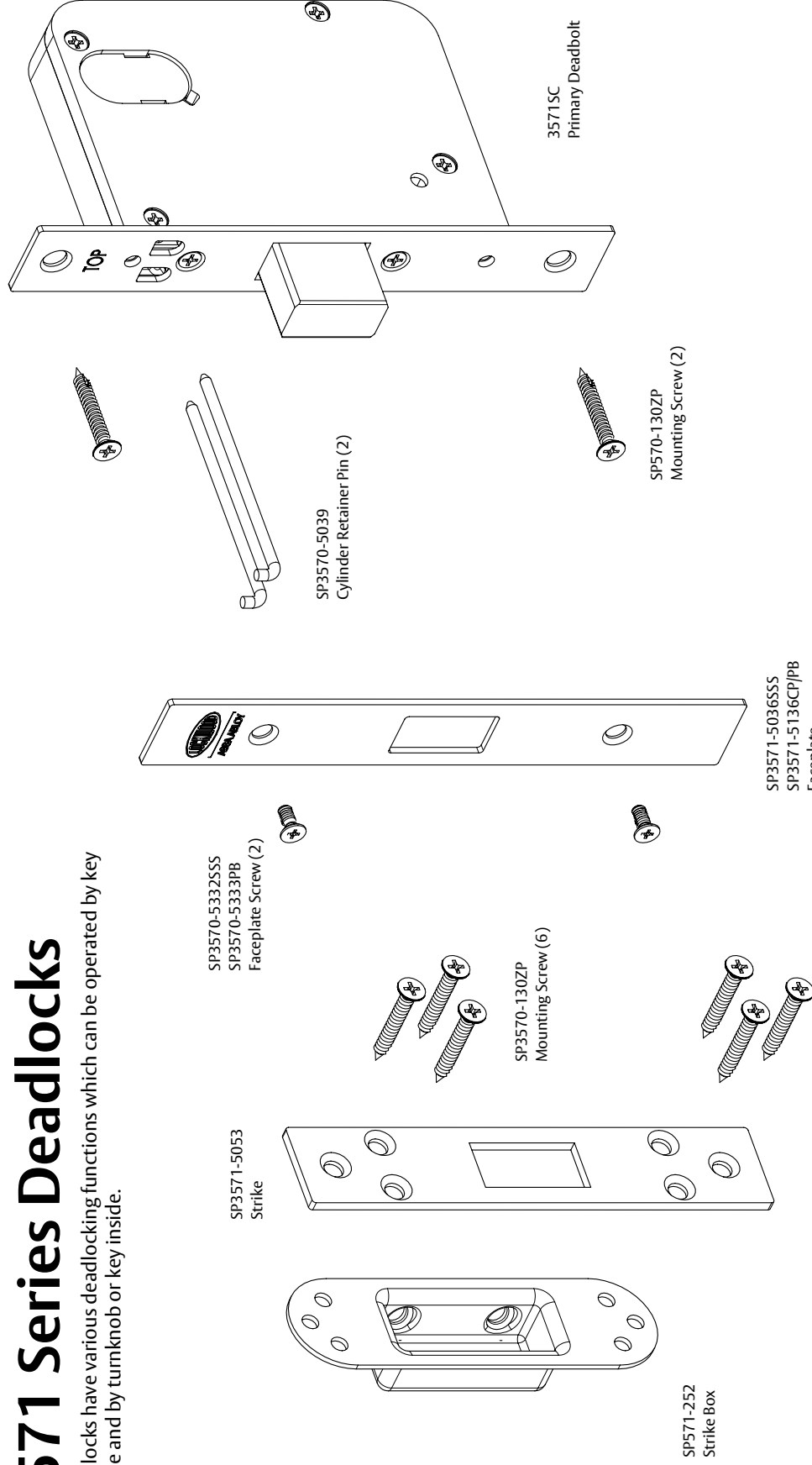

3571 Series Deadlock

Orderable Locks

3571SC*	Deadlock Primary Lock
3571TSC	Deadlock Primary Lock with Deadlock Turn Adaptor
3571AFSC	Deadlock Primary Lock Aluminium Fix
3571DELSNCYL	Escape Deadlock, LH Escape Turn and Adaptor
3571DERSNCYL	Escape Deadlock, RH Escape Turn and Adaptor
3571PTSC	Through Fix Privacy Deadbolt with Deadlock Turn Adaptor

3571 Series Deadlock Functions	
Cylinder and Turn Deadlock 3571WT	Exit Door Deadlock 3571-T
Double Cylinder Deadlock 3571YY	Single Cylinder Deadbolt 3571Y-
	Through Fix Privacy Deadlock 3571PT
	Escape Deadlock 3571DE

*Also available in Chrome Plate and Polished Brass finishes

3572/3574 Series Multi-Function Lock

These locks have various latching functions which can be operated by key or handle outside and by turnknob key or handle inside.

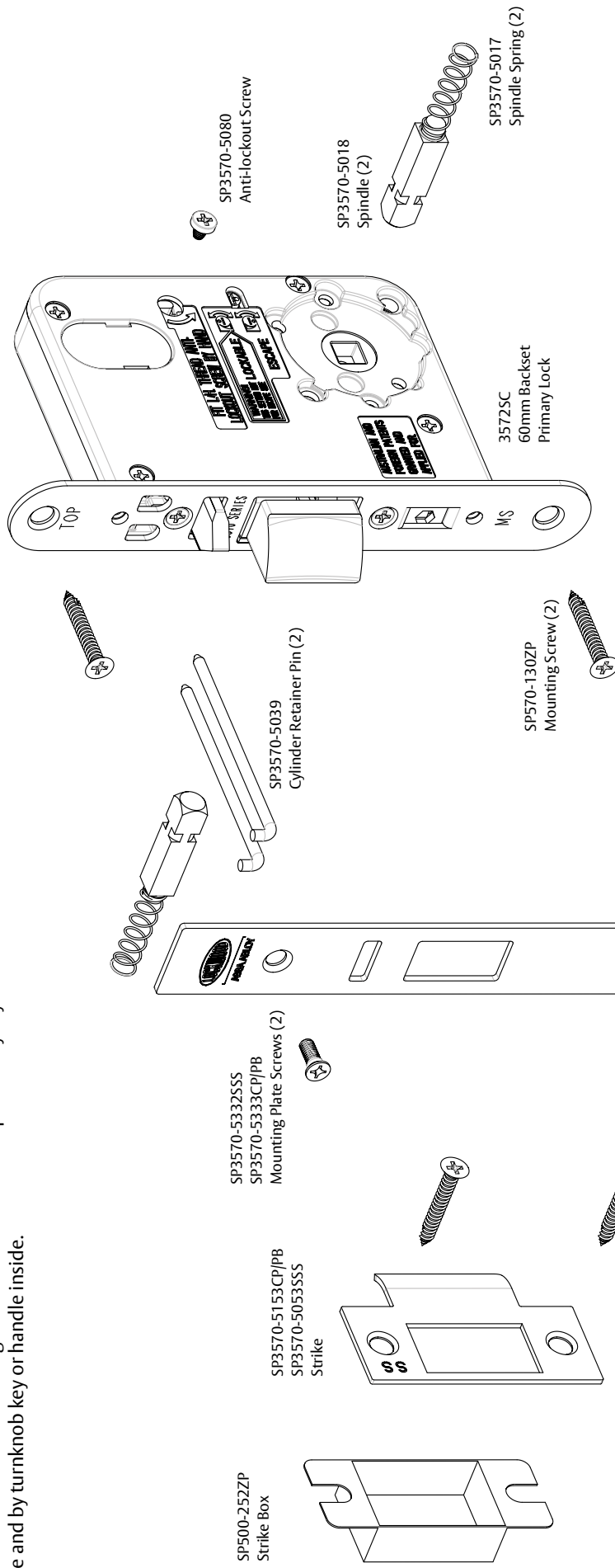

3572 Series Multi-Function Primary Lock

Orderable Locks

3572SC*	Multi-Function Primary Lock
3572AFSC	Multi-Function Primary Lock Aluminium Fix
3572SCM8	Multi-Function Primary Lock 8mm Furniture Hubs and Modric Spring
3572SCNOHD	Multi-Function Primary Lock no Hub Disc (Suits Aperio Esc)
3572XALSCNCYL	Anti-Vandal Anti-Lockout Lock Case and Adaptor Left Hand
3572XARSCNCYL	Anti-Vandal Anti-Lockout Lock Case and Adaptor Right Hand
3572TSC	Multi-Function Primary Lock with Turn Adaptor
3572M-LSC	Anti-Vandal Classroom Lock with M Cylinder Left Hand
3572M-RSC	Anti-Vandal Classroom Lock with M Cylinder Right Hand
3572XSC	Storeroom Lock - Primary Lock with X Cylinder
3572ZSC	Classroom Lock - Primary Lock with Z Cylinder
3572WASC	Anti-Lockout Lock - Primary Lock with W Cylinder and Turn Adaptor
3572XTSC	Entry Lock - Primary Lock with X Cylinder and Turn Adaptor
3574SC*	Passage Latch, Plainlatch only
3574AFSC	Passage Latch Aluminium Fix

SP3570-5036SSS
SP3570-5136CP/PB
Face Plate

*Also available in Chrome Plate and Polished Brass finishes

3572/3574 Multi-Function Lock Functions

Escape Function Locks

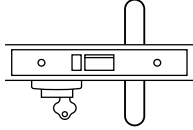

Storeroom Lock
3572X

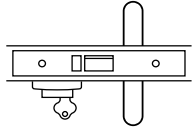

Classroom Lock
3572Z

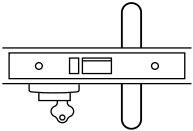

Anti-Vandal Classroom Lock
3572M

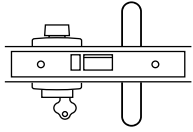

Entry Lock
3572XT

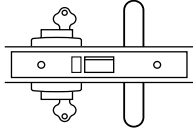

Double Cylinder Escape Lock
3572XZ

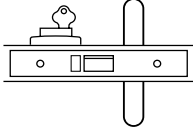

Single Cylinder Exit Lock
3572-Z

Escape Function Locks (continued)

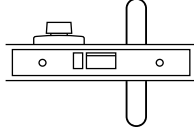

Exit Lock
3572-T

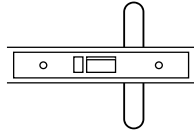

Exit Lock
3572-

Combination Function Locks

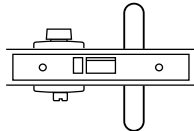

Privacy Lock
3574ET

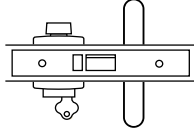

Office Lock
3574WT

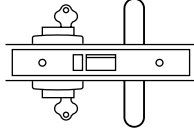

Glass Door Entry Lock
3574XZ

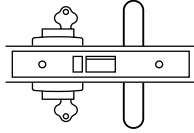

Double Cylinder Glass Door Lock
3574ZZ

Combination Function Locks (continued)

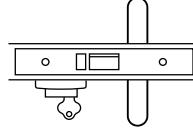

Glass Door Lock
3574Z

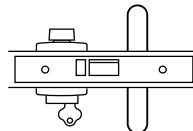

Anti-lockout Escape Lock
3572WA

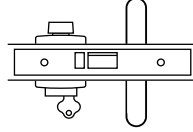

Anti-Vandal Door Lock
3572XA

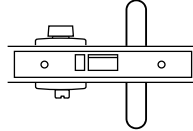

Anti-lockout Privacy Escape Lock
3572EA

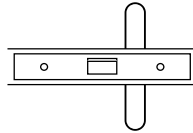

Passage Latch
3574-

3573 Series Sliding Door Deadlocks

These locks have various deadlocking functions which can be operated by key outside and by turnknob or key inside.

SP3571-5036SSS
SP3571-5136CP/PB
Faceplate

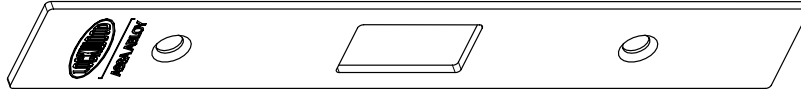

SP570-130ZP
Mounting Screw (6)

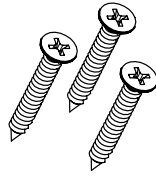

SP3570-5332SSS
SP3570-5333PB
Faceplate Screw (2)

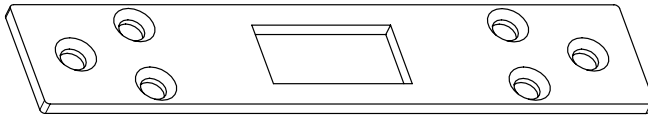

SP3571-5053
Strike

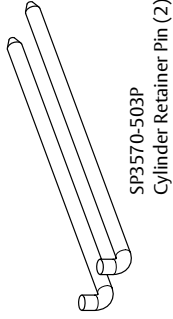

SP570-503P
Cylinder Retainer Pin (2)



SP570-130ZP
Mounting Screw (2)

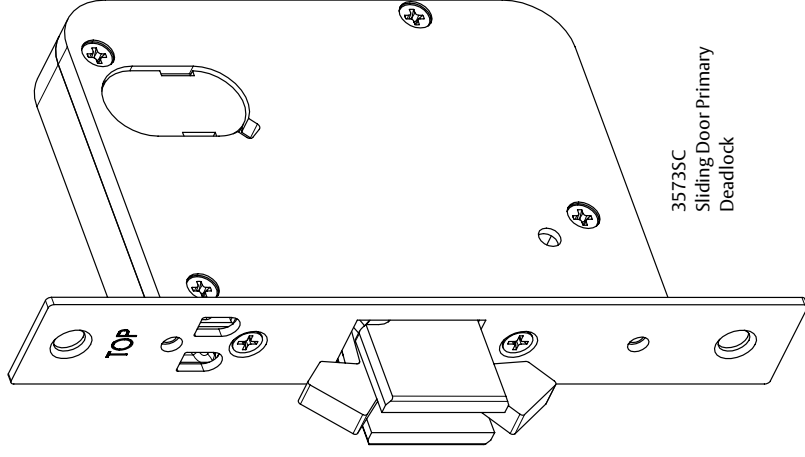

3573SC
Sliding Door Primary
Deadlock

3573 Series Sliding Door Deadlocks

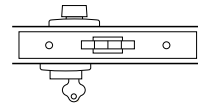

Sliding Door Cylinder
and Turn Deadlock
3573WT

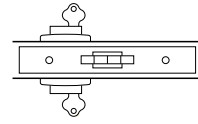

Sliding Door Double
Cylinder Deadlock
3573Y

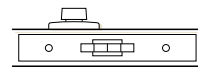

Exit Sliding
Door Deadbolt
3573-T

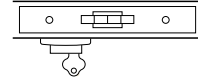

Single Cylinder Sliding
Door Deadlock
3573Y

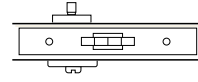

Sliding Door Through
Fix Privacy Deadlock
3573PT

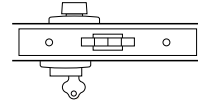

Sliding Door
Escape Deadlock
3573DE

3573 Series Sliding Door Deadlock

Orderable Locks

3573SC*	Sliding Door Deadlock Primary Lock
3573-TSC	Sliding Door Deadlock Primary Lock with Deadlock Turn Adaptor
3573AFSC	Sliding Door Deadlock Primary Lock with Aluminium Fixing Tabs
3573DELSNCYL*	Sliding Door Escape Deadlock, LH Escape Turn and Adaptor
3573DERSCNYL*	Sliding Door Escape Deadlock, RH Escape Turn and Adaptor
3573PTSC*	Sliding Door Through Fix Privacy Deadbolt with Deadlock Turn Adaptor

*Also available in Chrome Plate and Polished Brass finishes

3573 Series Sliding Door Deadlocks

These locks have various deadlocking functions which can be operated by key outside and by turnknob or key inside.

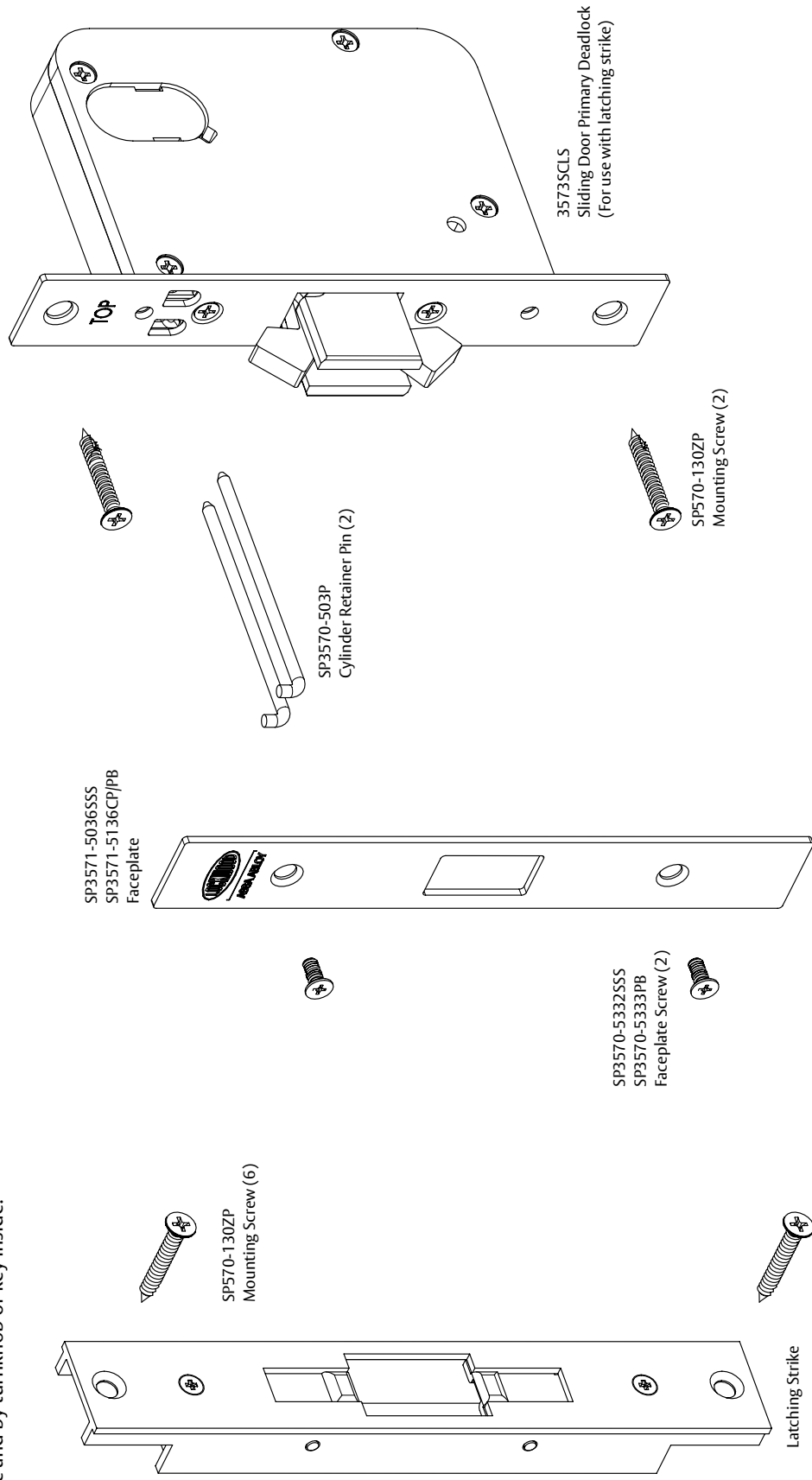

3573 Series Sliding Door Deadlock Self Latching

Orderable Locks

3573SCLS*	Sliding Door Deadlock Primary Lock with Latching Strike
3573AFSCLS	Sliding Door Deadlock Primary Lock with Aluminium Fixing Tabs with Latching Strike
3573DELSNCYLLS*	Sliding Door Escape Deadlock, LH Escape Turn and Adaptor with Latching Strike
3573DERSNCYLLS*	Sliding Door Escape Deadlock, RH Escape Turn and Adaptor with Latching Strike

*Also available in Chrome Plate and Polished Brass finishes

Note: Latching Strike is included with the above Lock kits. The lock has been specially modified to suit the latching strike.

3577 Series Dual Entry Lock

Designed to enable emergency services to enter specific areas by second cylinder without giving access to all lockset in the building and the ability to lockout keys with restricted access at certain times.

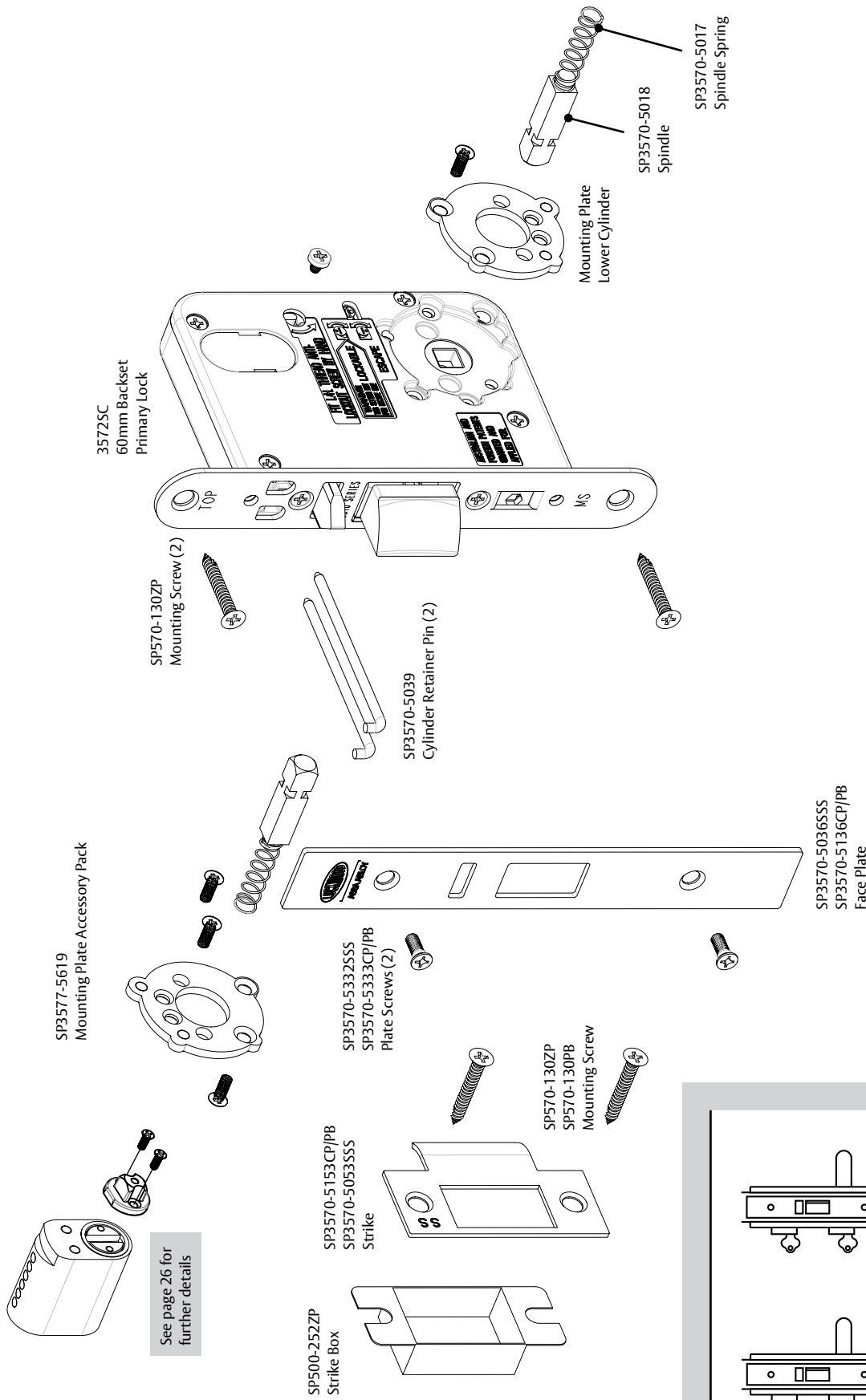

3577 Series Dual Locks

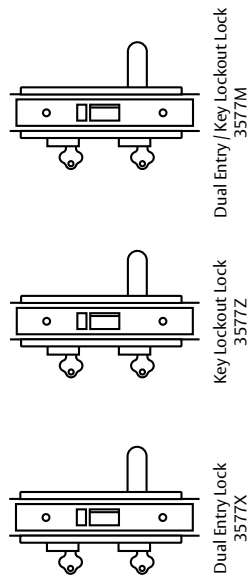

3577 Series Dual Entry Lock

Primary Lock

3577SC* Dual Entry Primary Lock - No Cylinders

* Also available in Chrome Plate and Polished Brass finishes.

3578 Series Holdback Lock

A deadlatching lockset for applications where latch hold - back is required such as high use doors and toilet doors.

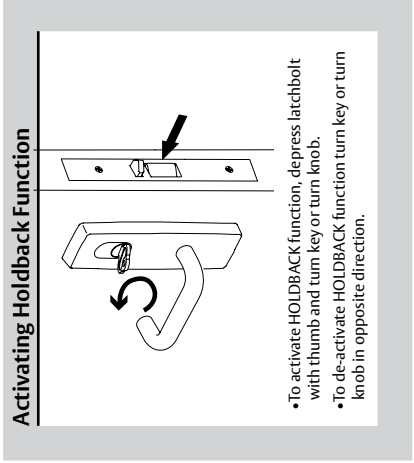
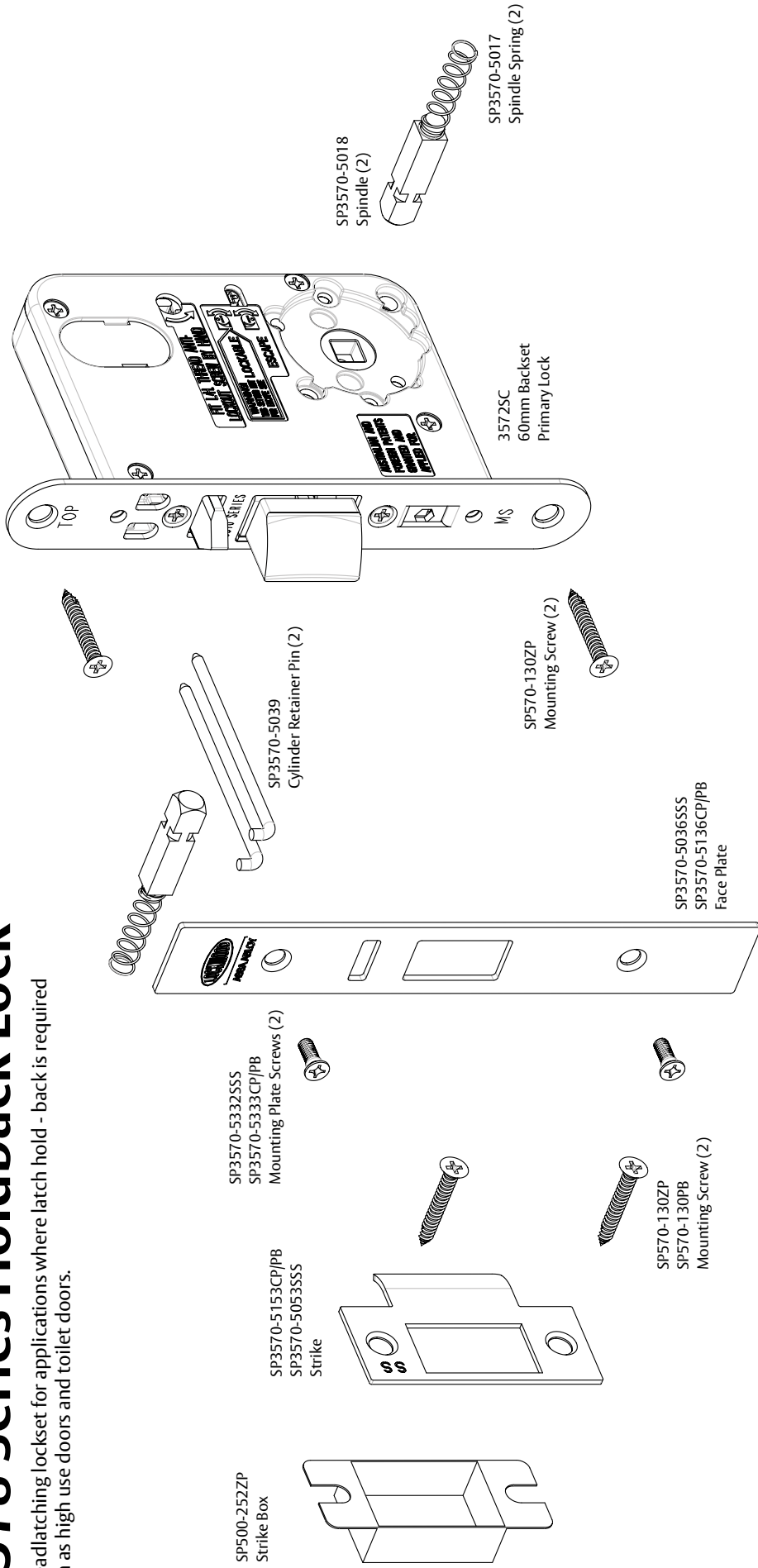

- To activate HOLDBACK function, depress latchbolt with thumb and turn key or turn knob.
- To de-activate HOLDBACK function turn key or turn knob in opposite direction.

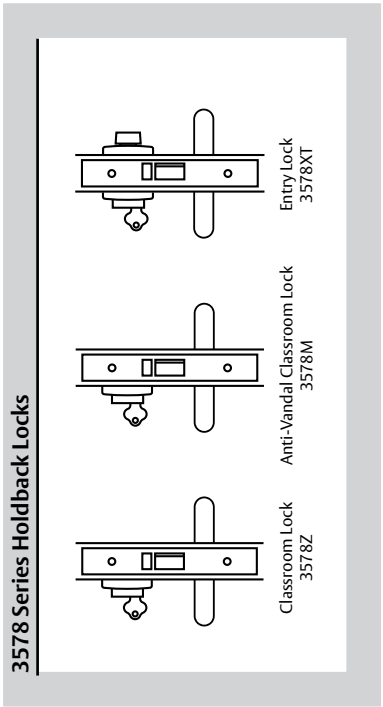

3578 Series Holdback Lock

Orderable Locks

3578SC*	Primary Mortice Lock Holdback
3578AFSC	Holdback Primary Lock Aluminium Fix

*Also available in Chrome Plate and Polished Brass finishes.

3579 Series SSEC Secure Area Mortice Locks

For use and high security Government, institutional and commercial projects.

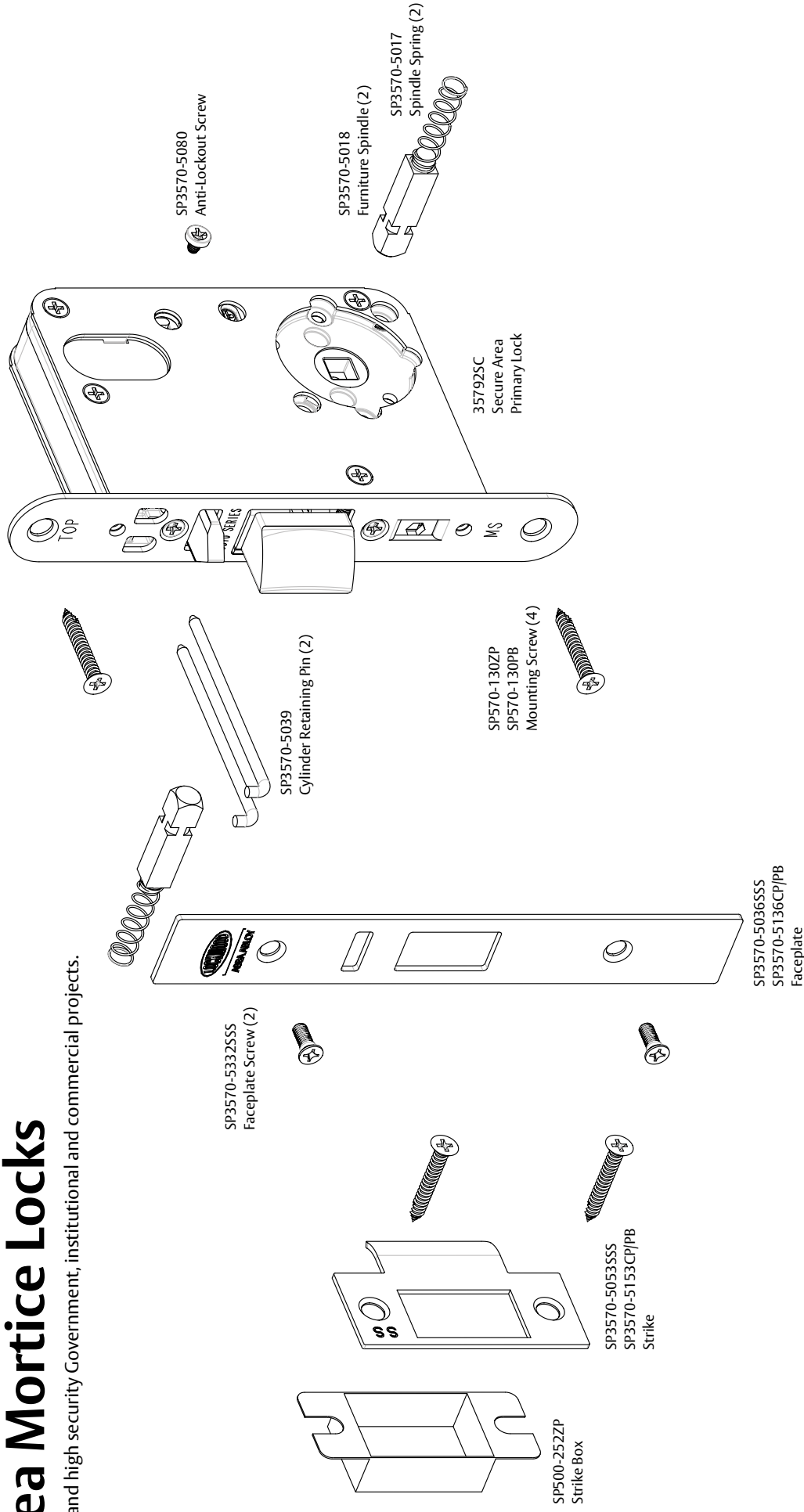

3579 Series Secure Area Rated Locks

Orderable Locks

35790SC	Secure Area Nightlatch Primary Lock
35791SC	Secure Area Deadbolt Primary Lock
35792SC	Secure Area Multi-Function Primary Lock

3572AF Aluminium Fix Lock

A deadlatching lockset for applications where latch hold - back is required such as high use doors and toilet doors.

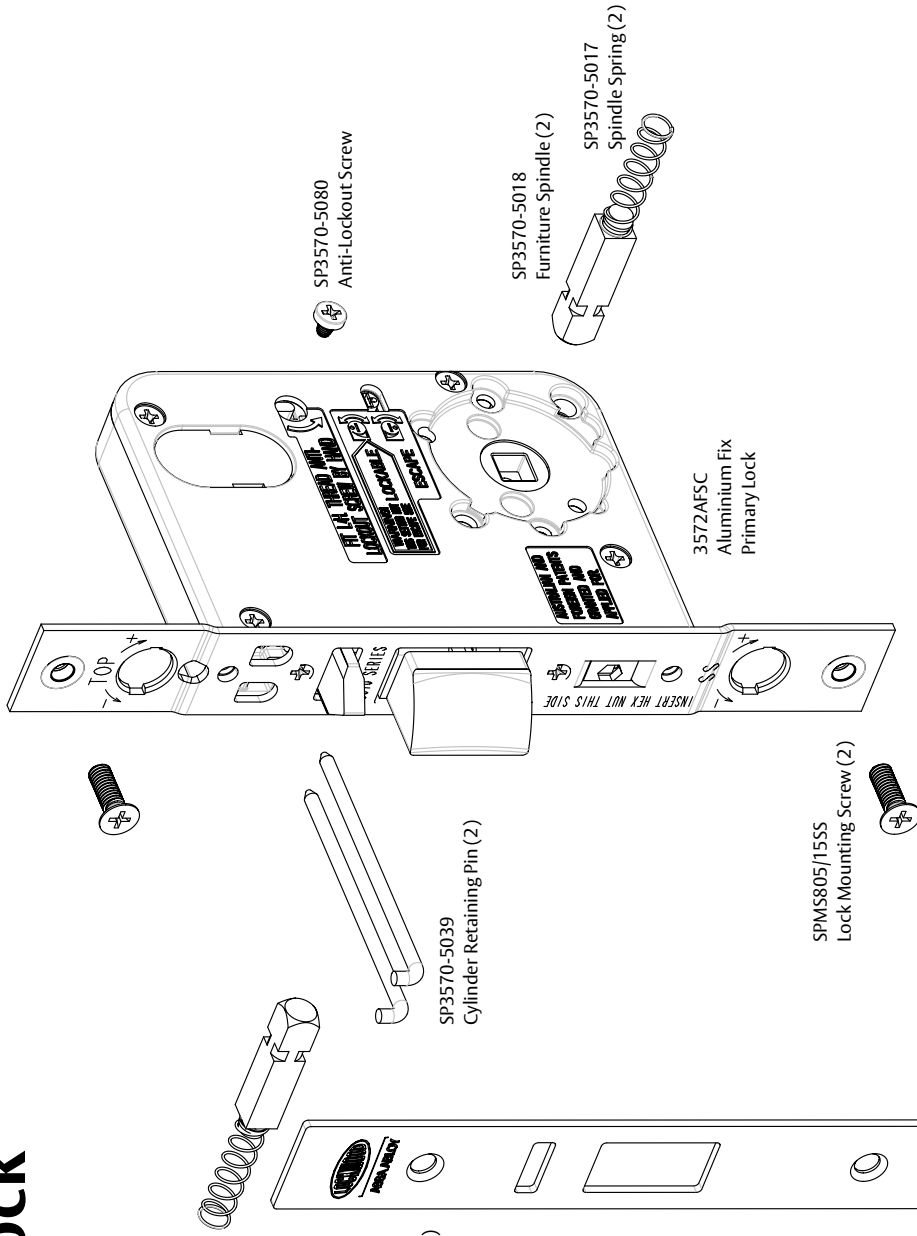
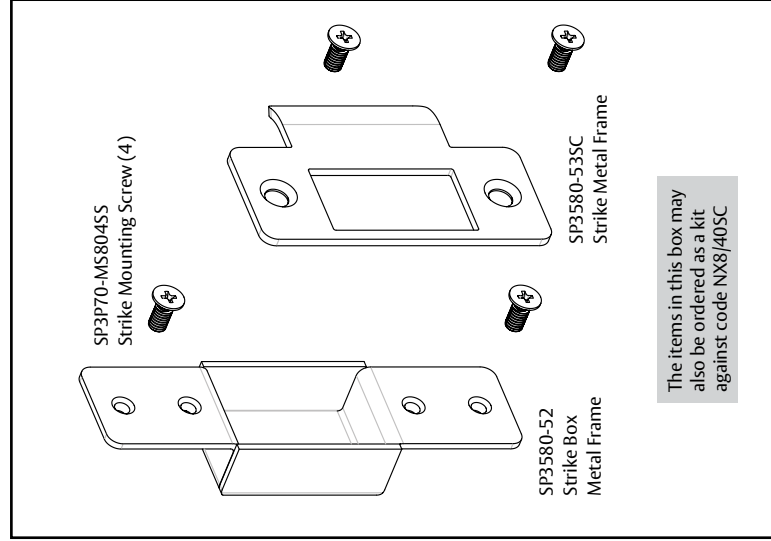

3570 Series Aluminium Fix Locks

Orderable Locks

3570AFSC	Nightlatch Primary Lock Aluminium Fix
3571AFSC	Deadlock Primary Lock Aluminium Fix
3572AFSC	Multi-function Primary Lock Aluminium Fix
3574AFSC	Passage Latch Aluminium Fix
3573AFSC	Sliding Door Deadlock Primary Lock Aluminium Fix
3573AFSCLS	Sliding Door Deadlock Primary Lock Aluminium Fix with Latching Strike
3578AFSC	Holdback Primary Lock Aluminium Fix

SP3570-5036SSS
SP3570-5136CP/PB
Faceplate

4570 Series 89mm Extended Backset Mortice Locks

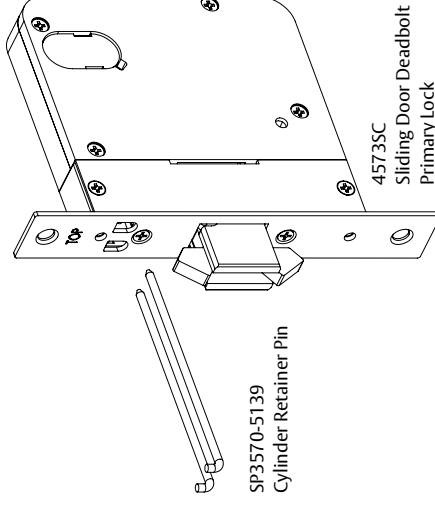
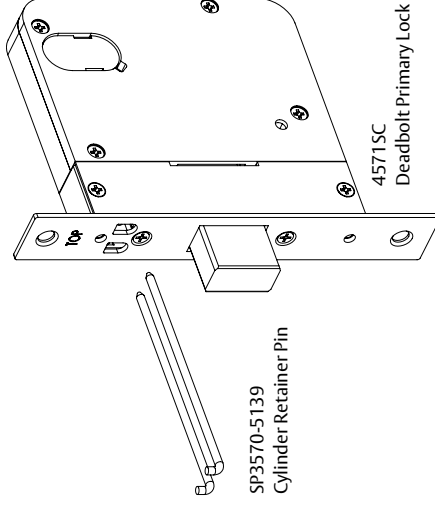
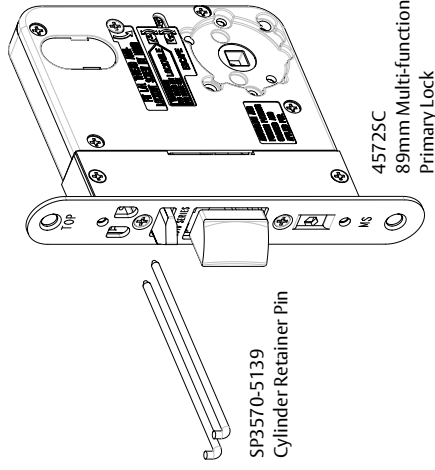

4570 Series 89mm Extended Backset Locks

Orderable Locks

4570SC*	Nightlatch Primary Lock
4571SC	Deadlock Primary Lock
4571AFSC	Deadlock Primary Lock with Aluminium Fixing Tabs
4571DELSNCYL	Escape Deadlock, LH Escape Turn and Adaptor
4571DERSNCYL	Escape Deadlock, RH Escape Tur and Adaptor
4571PTSC	Through Fix Privacy Deadbolt with Deadlock Turn Adaptor
4572SC*	Multi-function Primary Lock
4572AFSC*	Multi-function Primary Lock Aluminium Fix
4572XALSNCYL	Anti-vandal Anti-lockout Lock Case and Adaptor Left Hand
4572XARSNCYL	Anti-vandal Anti-lockout Lock Case and Adaptor Right Hand

4573SC*	Sliding Door Deadlock Primary Lock
4573AFSC	Sliding Door Deadlock Primary Lock with Aluminium Fixing Tabs
4573DELSNCYL*	Sliding Door Escape Deadlock, LH Escape Turn and Adaptor
4573DERSNCYL*	Sliding Door Escape Deadlock, RH Escape Turn and Adaptor
4573PTSC*	Sliding Door Through Fix Privacy Deadbolt with Deadlock Turn Adaptor
4573SCLS*	Sliding Door Deadlock Primary Lock with Latching Strike
4574SC*	Passage Latch, Plainlatch Only
4578SC*	Primary Mortice Lock Hold Back
4579TSC	Secure Area Deadbolt Primary Lock
4579JSC	Secure Area Multi-function Primary Lock

5570 Series 127mm Extended Backset Mortice Locks

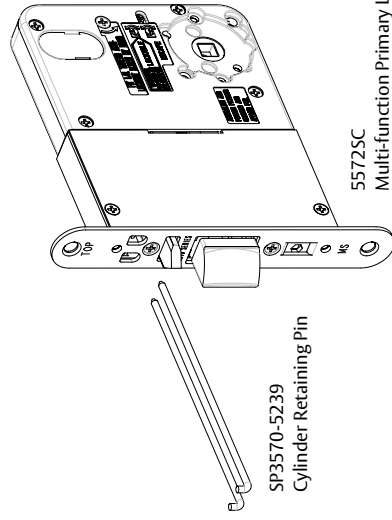

SP3570-5239
Cylinder Retaining Pin

5572SC
Multi-function Primary Lock

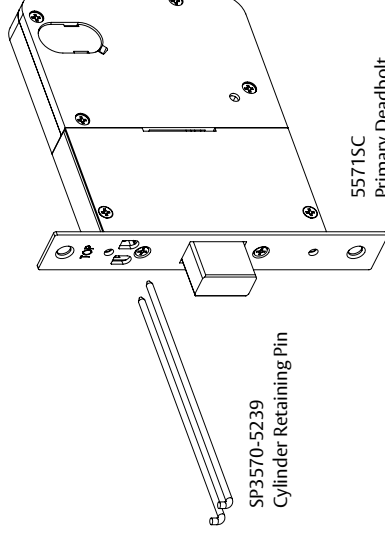

SP3570-5239
Cylinder Retaining Pin

5571SC
Primary Deadbolt

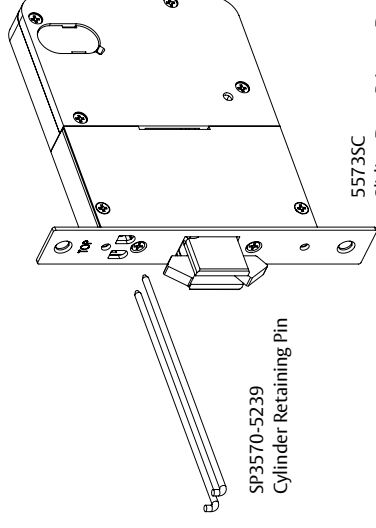

SP3570-5239
Cylinder Retaining Pin

5573SC
Sliding Door Primary Deadbolt

5570 Series 127mm Extended Backset Locks

Orderable Locks

5570SC*	Nightlatch Primary Lock
5571SC*	Deadlock Primary Lock
5571AFSC	Deadlock Primary Lock with Aluminium Fixing Tabs
5571DELSNCYL	Escape Deadlock, LH Escape Turn and Adaptor
5571IDERSNCYL	Escape Deadlock, RH Escape Turn and Adaptor
5571PTSC	Through Fix Privacy Deadbolt with Deadlock Turn Adaptor
5572SC*	Multi-function Primary Lock
5572AFSC	Multi-function Primary Lock Aluminium Fix
5572XALSNCYL	Anti-vandal Anti-lockout Lock Case and Adaptor Left Hand

5572XARSNCYL

Anti-vandal Anti-lockout Lock Case and Adaptor Right Hand

5573SC* Sliding Door Deadlock Primary Lock

5573AFSC Sliding Door Deadlock Primary Lock with Aluminium Fixing Tabs

5573DELSNCYL* Sliding Door Escape Deadlock, LH Escape Turn and Adaptor

5573IDERSNCYL* Sliding Door Escape Deadlock, RH Escape Turn and Adaptor

5573PTSC* Sliding Door Through Fix Privacy Deadbolt with Deadlock Turn Adaptor

5573SCLS* Sliding Door Deadlock Primary Lock with Latching Strike

5574SC* Passage Latch, Plainlatch Only

5578SC* Primary Mortice Lock Hold Back

55791SC Secure Area Deadbolt Primary Lock

55792SC Secure Area Multi-function Primary Lock

Cylinders

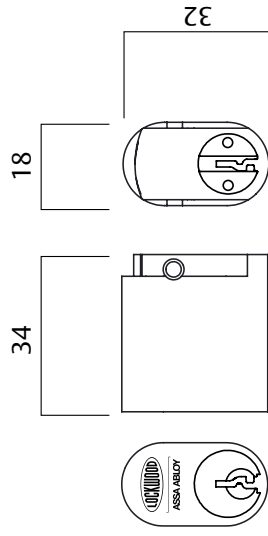

Synergy Series

"X" CAM SP570-18ZP	"Y" CAM SP571-18ZP	"Z" CAM SP572-18ZP	"W" CAM SP575-18ZP	"M" CAM W mounted upside down	"XA-L" CAM SP3572-6118	"XA-R" CAM SP3572-6218

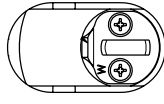

"W" Cam Cylinder 575-52SC
Cam Separately SP575-18ZP

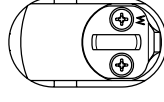

"W" Cam Cylinder 575-52SC
Cam Separately SP575-18ZP
"fitted upside down"

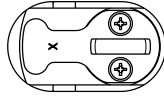

"X" Cam Cylinder 570-25C
Cam Separately SP570-18ZP

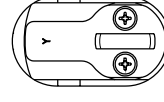

"Y" Cam Cylinder 571-25C
Cam Separately SP571-18ZP

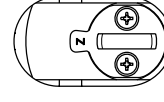

"Z" Cam Cylinder 572-25C
Cam Separately SP572-18ZP

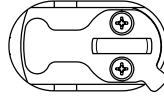

"XA-L" Cam Cylinder 570-302LHSC
Cam Separately SP3572-6118

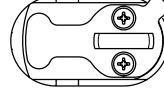

"XA-R" Cam Cylinder 570-302RHSC
Cam Separately SP3572-6128

Standard 570 cylinder

This cylinder is used on Lockwood Cylinder Mortice Locks. The Synergy series uses various cylinder cams depending on the function required. Cylinder is assembled as a 5 pin tumbler mechanism but is 6 pin tumbler capable. Uses a standard 570 barrel.

Standard "C4" Assembled Cylinder Part Number

570-25C	Mortice Cylinder with "X" cam
571-25C	Mortice Cylinder with "Y" cam
572-25C	Mortice Cylinder with "Z" cam
575-25C	Mortice Cylinder with "W" cam
575-52SC	Mortice Cylinder with "M" cam
570-302LHSC	Mortice Cylinder with "XA" cam Left Hand
570-302RHSC	Mortice Cylinder with "XA" cam Right Hand

Cylinders

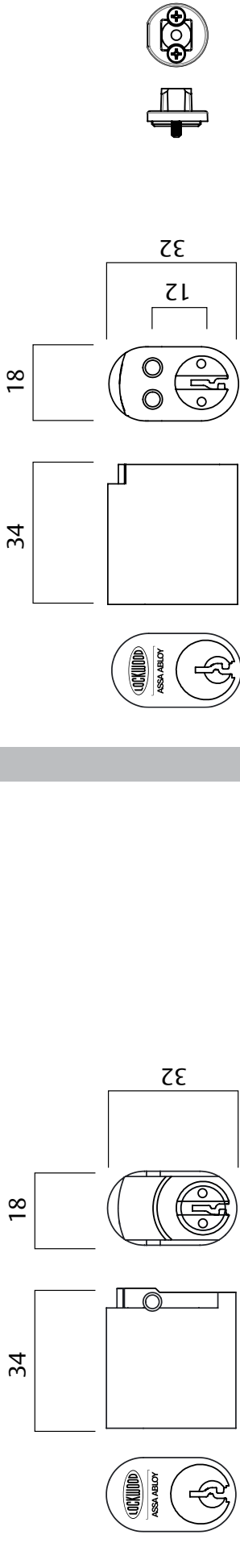

H/B CAM RETAINER PLATE
SP3570-5118

3580 H/B CAM
SP3580-5125

RH 3570 H/B CAM
SP3570-5125

LH 3570 H/B CAM
SP3580-5625

Synergy Hold Back Cylinder

This cylinder is used on Lockwood Synergy Mortice Locks for a hold back function. It has a stepped back and the cam assembly is made up of two pieces - the cam and the retainers plate. Cylinder is assembled as a 5 pin tumbler mechanism but is 6 pin tumbler capable. Uses special hold back barrels (570 barrels will not fit with this application)

Standard "C4" Assembled Cylinder Part Number

3580-2402SC	Synergy Hold Back Cylinder RH for 3580 series
3580-2452SC	Synergy Hold Back Cylinder LH for 3580 series
3570-2402SC	Synergy Hold Back Cylinder RH for 3570 series
3570-2452SC	Synergy Hold Back Cylinder LH for 3570 series

Note: Handling assumes the cylinder is fitted to the outside of the door

Synergy Dual Lower Cylinder

This cylinder is used as the dual lower cylinder in the Synergy range. Also used for the Inline Airlock (trailer lock). This cylinder is not compatible with the new Pentagon series dual cylinder function. Cylinder is assembled as a 5 pin tumbler mechanism but is 6 pin tumbler capable. Uses a standard 570 barrel.

Standard "C4" Assembled Cylinder Part Number

577-25C	Synergy Dual Lower Cylinder for 3577 series
---------	---

Cylinders

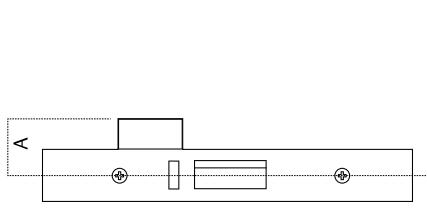
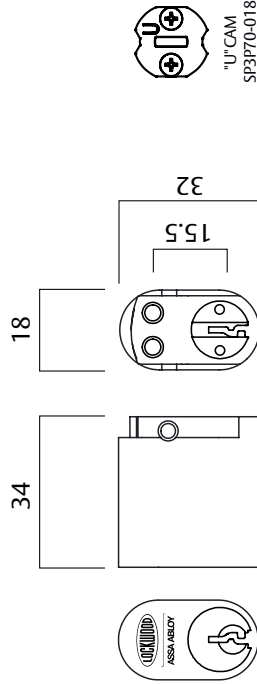

Screws

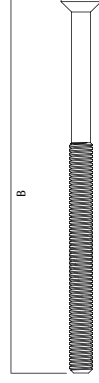

Screws are available in 4 sizes which can be cut and deburred to the desired length.

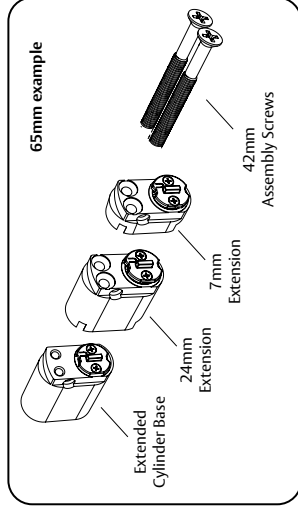
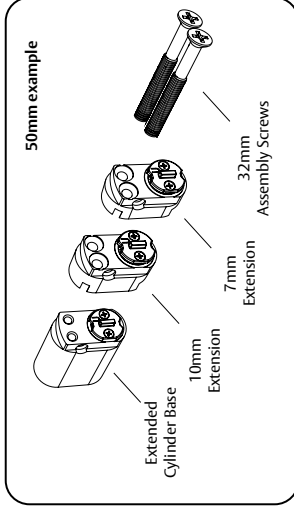

An extension guide is included to show the parts required for a particular length:

Overall Cylinder Length Required	Cylinder Projection (A)	Door Thickness	Extended base Cylinder	7mm Extension Kit	10mm Extension Kit	24mm Extension Kit	32mm Assembly Screw	42mm Assembly Screw	65mm Assembly Screw
34	36	35	49						
41	43	49	63	1	1				2
50	53	63	83	1	1	1	1		2
61	63	83	103	1	1	2		2	
65	67	93	98	1	1	1	1		2
72	74	103	123	1	2	1			2
82	84	123	143	1		2	2		2
92	94	143	163	1	1	2			2

Standard Mortice Cylinder

Assembly Screws

Part Number	Pack Size	Length(B)	Min-Max Extension (mm) If screw uncut
SRWM4-3ZSS	10	32	7-24
SRWM4-4ZSS	10	42	14-36
SRWM4-65SS	10	65	37-58
SRWM4-75SS	10	75	47-68

Extension Kits

Part Number	Pack Size
570 EXT07	5 7mm Extension Kit
570 EXT10	5 10mm Extension Kit
570 EXT24	5 24mm Extension Kit

Extended Cylinder Base

This cylinder is used for the extended cylinder base to build extended cylinders using the Lockwood modular system. This cylinder is not compatible with the old Synergy series dual cylinder function or the Inline Airlock. Cylinder is assembled as a 5 pin tumbler mechanism but is 6 pin tumbler capable. Uses a standard 570 barrel.

Standard "C4" Assembled Cylinder Part Number

570E 5C	Extended Cylinder Base with "U" cam
570E 50WSC	50mm Extended Cylinder Assembly with "W" cam
570E 50XSC	50mm Extended Cylinder Assembly with "X" cam
570E 50ZSC	50mm Extended Cylinder Assembly with "Z" cam
570E 65WSC	65mm Extended Cylinder Assembly with "W" cam
570E 65XSC	65mm Extended Cylinder Assembly with "X" cam
570E 65ZSC	65mm Extended Cylinder Assembly with "Z" cam

3570 Series Alternative Finish Kits

Non standard finish kits include: Strike, Faceplate and Screws

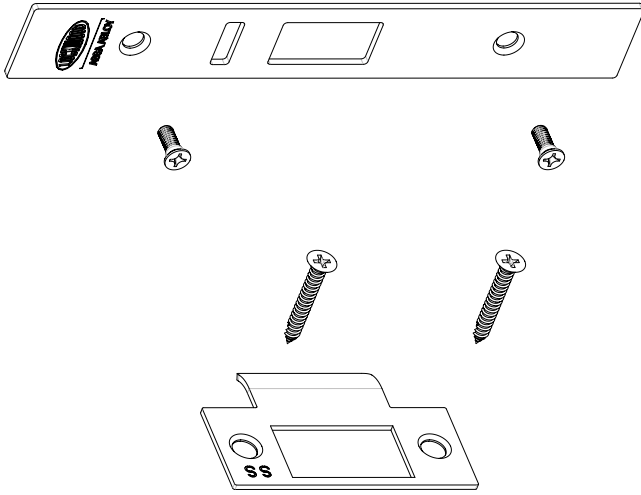

Alternative Finish Kits

3570 Series Non-standard Finish Kit Includes: Strike, Face Plate & Screws

3570-AZKIT	Architectural Bronze
3570-CPKIT	Chrome Plate
3570-ORBKIT	Oil Rubbed Bronze
3570-PBKIT	Polished Brass
3570-BUKIT	Polished Brass Unlaquered
3570-PCKIT	Powder Coat

3580 Series Alternative Finish Kits

Non standard finish kits include: Strike, Faceplate and Screws

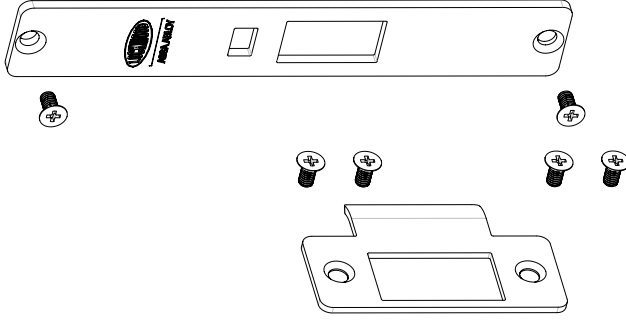

Alternative Finish Kits

3580 Series Non-standard Finish Kit Includes: Strike, Face Plate & Screws

3582-CPKIT	Chrome Plate
3582-PBKIT	Polished Brass
3582-PCKIT	Powder Coat

Rebate Kit - to suit 3570 Series Locks (4HR Fire Rated)

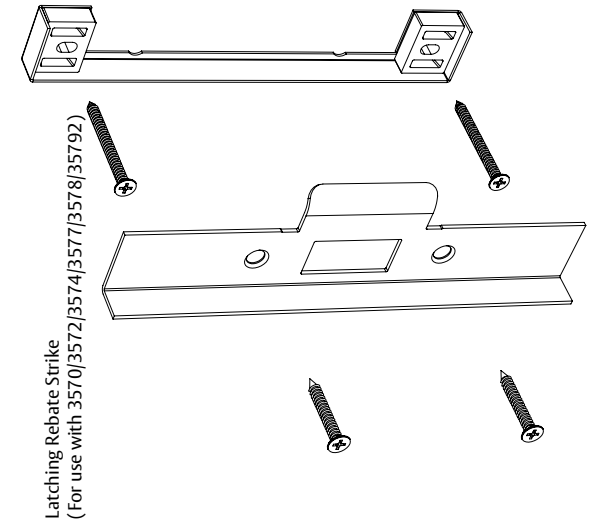

Latching Rebate Strike
(For use with 3570/3572/3574/3577/3578/35792)

3571-2902
Deadlock Rebate Strike
(For use with 3571/3573)

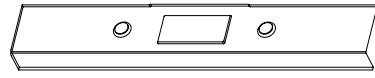

Lip Length	Rebate Kit Part Number
32mm	3P72 - RK32SS
46MM	3P72 - RK46SS
No Lip	3571 - 2902SC

Rebate Kit - to suit 3580 Series Locks

For use with a minimum of 30mm backset lock (5582)

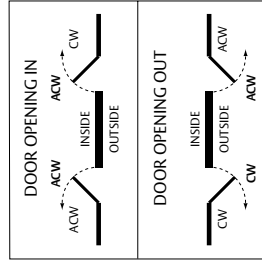
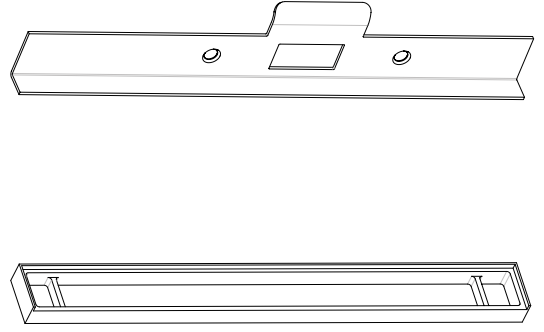

CW (Clockwise)
Left Hand open in
Right Hand open out

ACW (Anti-Clockwise)
Left Hand open out
Right Hand open in

Part Numbers

Chrome Plate	3580-2902	CW / ACW CP
Satin Chrome Brushed	3580-2902	CW / ACW SC
Polished Brass	3580-2902	CW / ACW PB

*Specify door handing (clockwise/anti-clockwise).

Accessories

3570 Series Aluminium Door Mounting Brackets

Can be used to mount any standard 3570 Series lock into a hollow section.

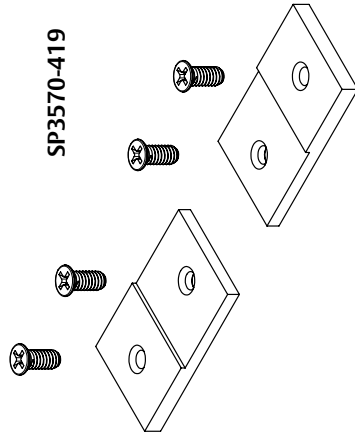

SP3570-419

Mortice Lock Spindles

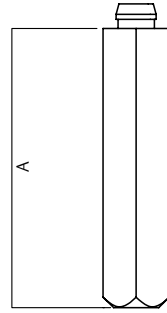

Part Number	Pack Size	Length "A"	Door Thickness	
			Min	Max
SP3570 - 5018	10	33mm	35	50
SP3570 - 5228	10	45	50	75
SP3570 - 5238	1	58	75	100
SP3570 - 5258	10	108	100	200
SP3570 - 5328	10	125	200	240

Note: 33mm length supplied in accessory pack with primary lock.

Strike Plate Kits

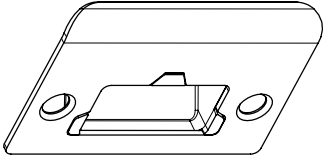

Standard Fabricator Strike 32mm
SP3P80 - 053SS

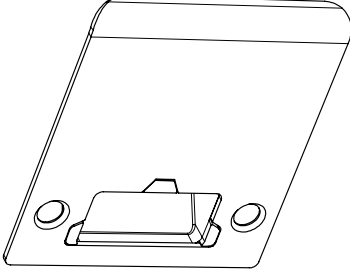

Extended Fabricator Strike 64mm
SP3P80 - 153SS

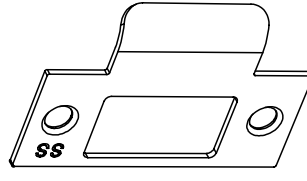

Standard Strike
SP3570 - 5053SSS

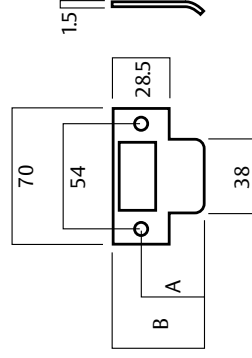

Standard Strike Plate "A"

SP3570-4053	25.4mm
SP3570-5053	32mm
SP3570-5253	43.5mm
SP3570-5453	47.5mm

Note: Dimension "B" is "A" plus 14mm

Retrofit Strikes

For replacement of existing installations where Lockwood 5900, 595 and Astra Short Backset are used. For replacement of Astra specify 25.4mm backset.

Part Numbers

Chrome Plate	3580-1902CP
Satin Chrome Brushed	3580-1902SC
Polished Brass	3580-1902PB

Adaptors

If using Case Fix Turns or Robert Watson turns a notched turn adaptor is required. Simply change the 5 after the dash to a 6 ie. SP3572-5250 becomes SP3572-6250.

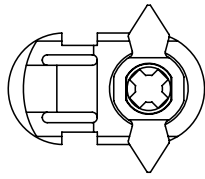

SP3572-5250
Standard Turn Adaptor

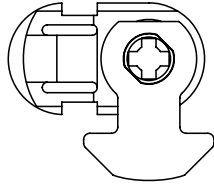

SP3570-5050
Nightlatch Turn Adaptor

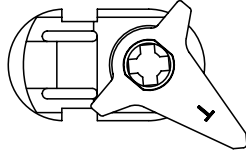

SP3571-5050
Deadlock Turn Adaptor

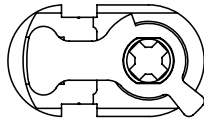

SP3572-5350
Anti-vandal Turn Adaptor (RH)

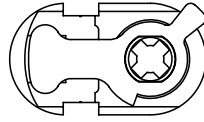

SP3572-5450
Anti-vandal Turn Adaptor (LH)

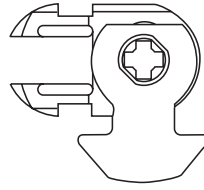

SP3570-6050
Nightlatch Turn Adaptor
(for Case Fix Turns)

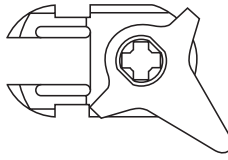

SP3571-6050
Deadlock Turn Adaptor
(for Case Fix Turns)

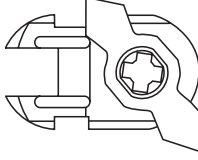

SP3572-6250
Standard Turn Adaptor
(for Case Fix Turns)

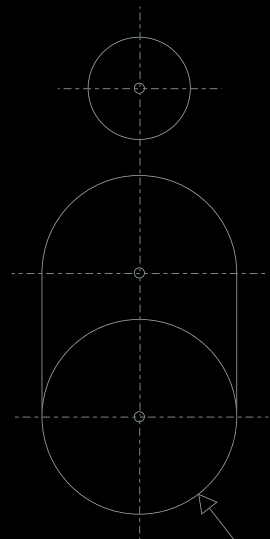
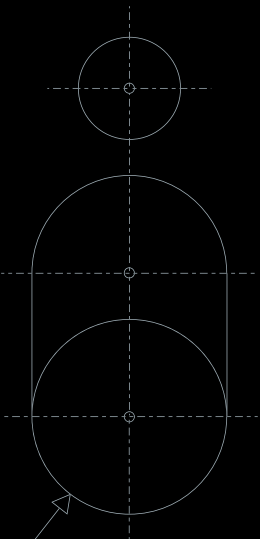

Mounting Instructions and Templates

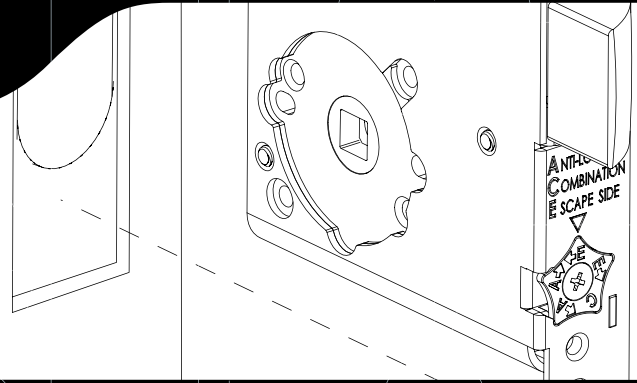
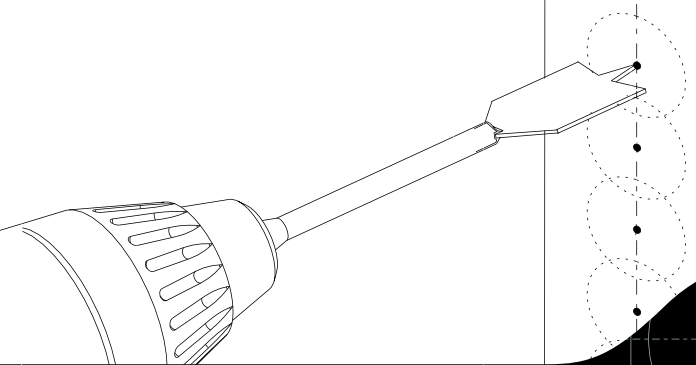



ASSA ABLOY

3572 SERIES MORTICE LOCK MOUNTING INSTRUCTIONS

P/No. 3570-5121 30621 0508

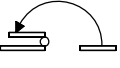
HAND OF DOOR ACCORDING TO ENGLISH PRACTICE

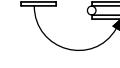
RIGHT - HAND DOOR		LEFT - HAND DOOR	
			
OUTSIDE DOOR OPENING IN	OUTSIDE DOOR OPENING OUT	OUTSIDE DOOR OPENING IN	OUTSIDE DOOR OPENING OUT

- Determine hand of lock required from hand of door chart above.
- All Lockwood 3572 Series Mortice Locks are mounted in accordance with these instructions. Locks may or may not have cylinders, lever handles, turn knob or emergency button. Disregard instructions referring to the features not required.
- Important : Before drilling door, ensure correct hand is being installed.
- NOTE: CASE DOES NOT need to be opened, to change HAND or FUNCTION of LOCK.

HANDING OF LOCK

- Determine hand of lock required from above hand of door chart.
- Rotate bolt head to suit latching direction.

1 SETTING LOCK STATUS

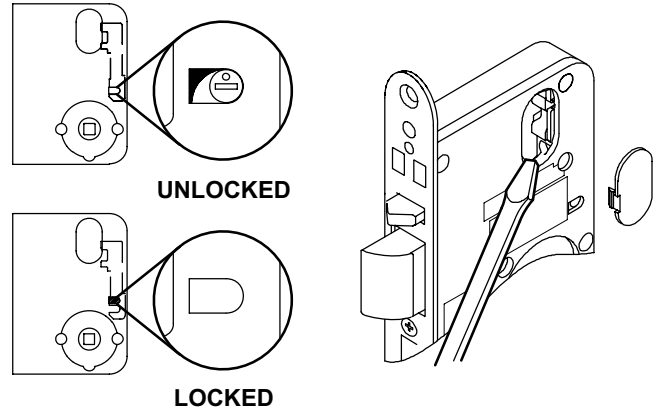

- Ensure lock is in UNLOCKED position.
- To UNLOCK (if required), using a small screwdriver, lever out Cylinder Hole Plug where fitted and lift snib using the screwdriver.

2 SETTING LOCK STATUS

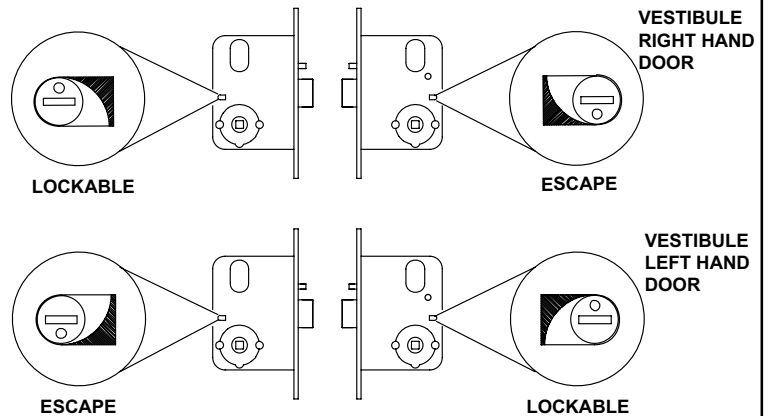
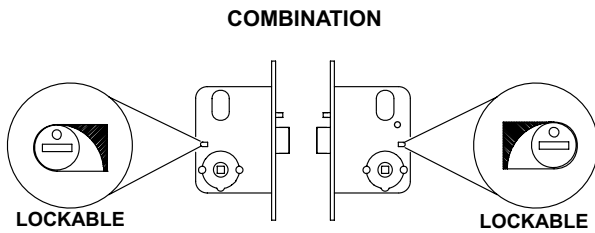

- **SNIB CAM**
Rotation of the Snib Cam hands the lock. Use a small screwdriver to rotate cam if required.
- **Combination locks**
(Both handles can be locked) DOT in the up position.

- **Vestibule Locks**
With single action escape feature. DOT to be DOWN on ESCAPE side and UP on LOCKABLE side.

3 SETTING KICK-OFF FUNCTION

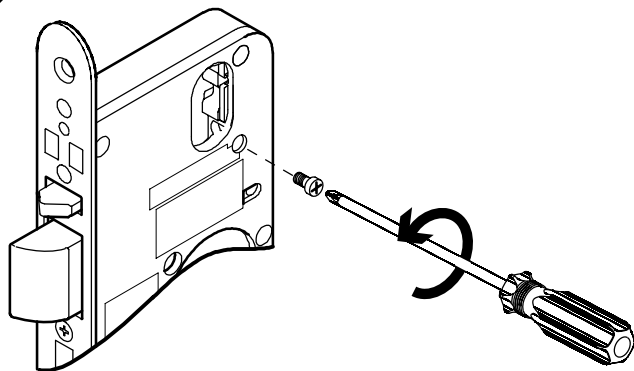

- To activate KICK-OFF function, ensure the lock is unlocked, then insert the KICK-OFF screw as shown. Rotate screw in the direction of the arrow as the screw is left hand thread.
Do not use power driver for this application as you may strip the screw thread.

4 TURN KNOB ADAPTORS

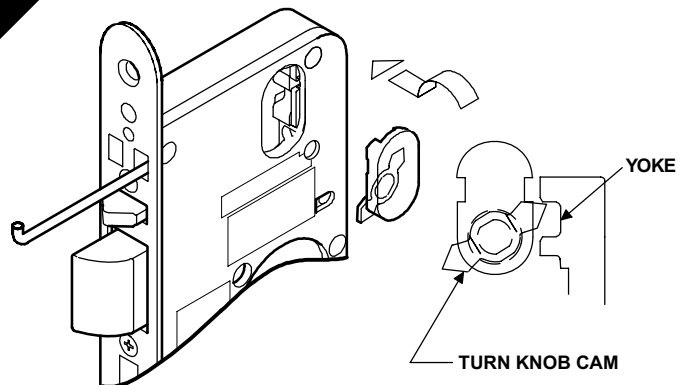

- Establish which side the adaptor is to be located, lever out Cylinder hole plug where fitted.
- **PUT LOCK IN LOCKED POSITION, as shown in Step 1.**
- Insert Adaptor into lock body with TOP of Turn Knob Cam point away from front of lock body. **Ensure Turn Knob Cam is engaged in yoke of snib as shown.**
- Place retainer pin through front plate to retain adaptor to lock. Ensure pin is flush with front plate

3572 SERIES MORTICE LOCK MOUNTING INSTRUCTIONS

5 DOOR PREPARATION

IMPORTANT - To prevent damage to the door face from drill "breakthrough", MARK BOTH SIDES OF DOOR & DRILL HOLES HALF WAY THROUGH EACH SIDE

- Establish height that lockset will be mounted on door and mark centreline of door thickness on door edge.
- Place Mortise Template on door and align centreline on template with centreline on door. Secure with sticky tape.
- Mark and drill mortise to suit mortise lock depth (90mm).

6 DOOR PREPARATION

- Ease out mortise cavity where necessary. Clean out mortise before inserting lock.
- Insert lock in mortise with Cover Plate on and scribe around Cover Plate for size of recess, ensuring that no foreign matter finds its way into the lock mechanism.
- Remove lock from mortise and chisel recess 4mm deep to receive both front and cover plate. Cover plate must be flush with edge of door.
- Ensure lock is removed from mortise cavity. Fold template along backset fold line. Align EDGE A with bottom of cover plate recess. Establish holes required to suit lock function, mark hole centres accurately, drill and clean holes.
- Drill furniture holes as required.
- Fasten mortise lock into door using mounting screws provided.

7 LOCKS AND CYLINDERS

LOCKS WITH CYLINDERS

- Place lock in mortise and insert cylinder.
- Secure cylinder with retainer pin, ensuring pin is flush with front plate.
- Install Cover plate and secure with 2 M4 screws provided to lock body.

LOCKS WITHOUT CYLINDERS

- Install Cover plate and secure with 2 M4 screws provided to lock body.

8 LOCKS WITH TURNKNOBS

LATCHING OR LOCKING TURNKNOB

EMERGENCY TURNKNOB FUNCTION

- Mark and cut connecting bar as shown.
- Turn knob to be in the vertical position when UNLOCKED.

9 LOCKS WITH SPINDLES

IMPORTANT: Attach spindle spring to rear of spindle before assembling

- All locks are supplied with spindles.
- Insert spindle(s) into lock, as required.
- Assemble furniture as required. Ensure furniture is not over-tightened.

10 MOUNTING STRIKE

- Mark out door frame for strike.
- Mortise door frame for strike box and strike. Bolt recess to be 15mm deep in door frame.
- Screw strike and strike box to the door frame with two screws supplied with mortise lock.

3570 SERIES MORTICE LOCK MOUNTING INSTRUCTIONS

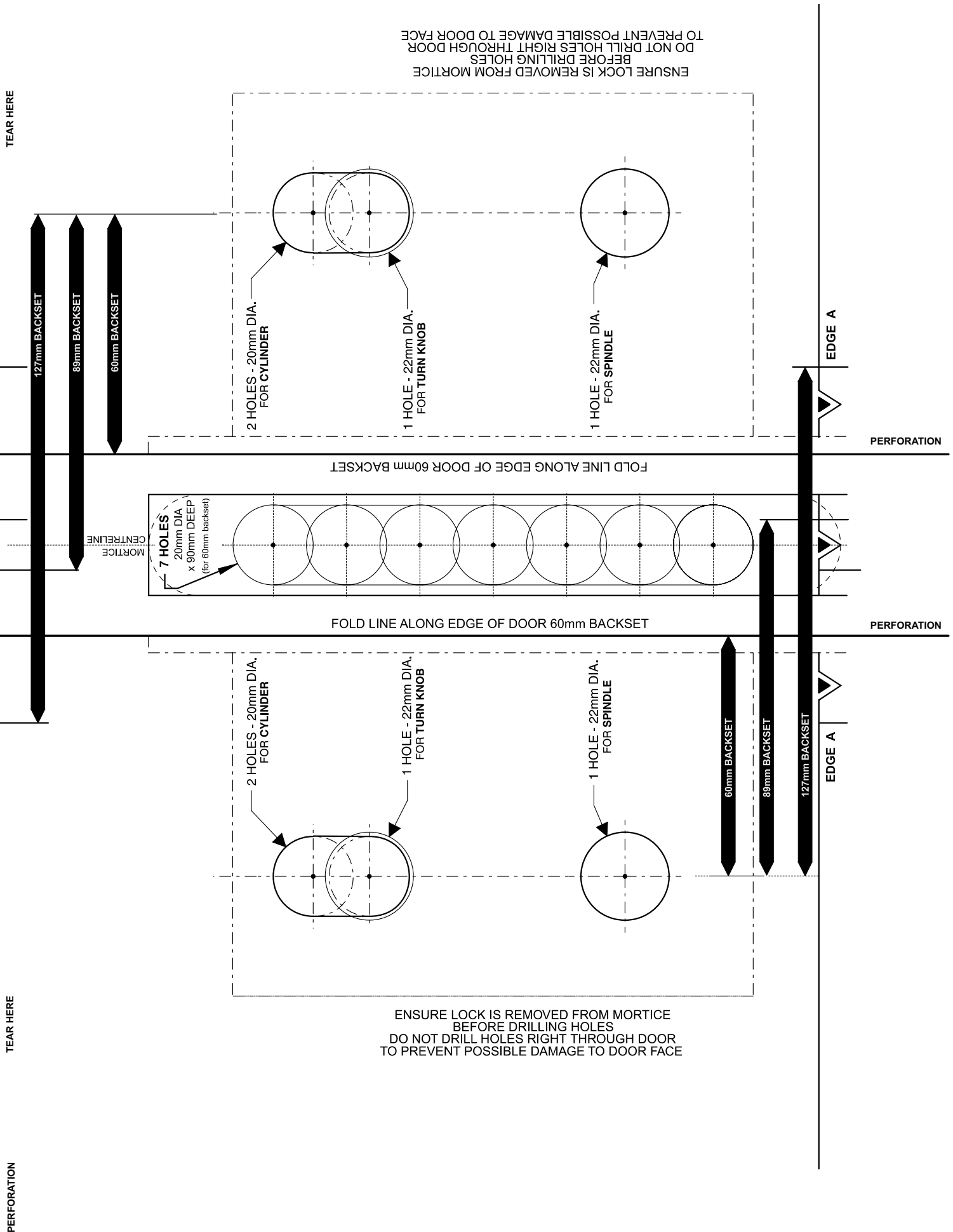

3570AF SERIES MORTICE LOCK

INSTALLATION INSTRUCTIONS WIDE ALUMINIUM STYLE DOORS

Part No. 3570AF-21 30621 0508

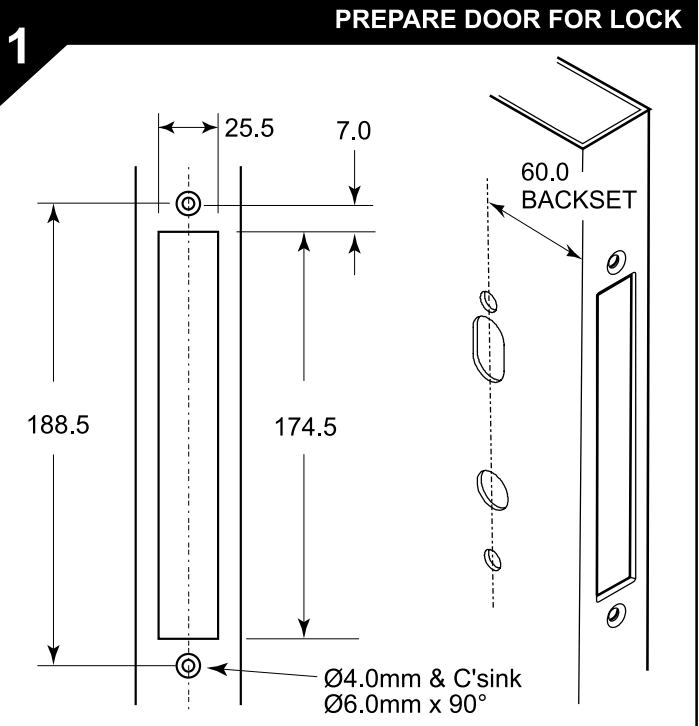

- Establish height at which lockset will be on door.
- Cut COVER PLATE window as per dimensions above.
- Using instructions and template from main instruction drill the holes for the cylinder, furniture etc.

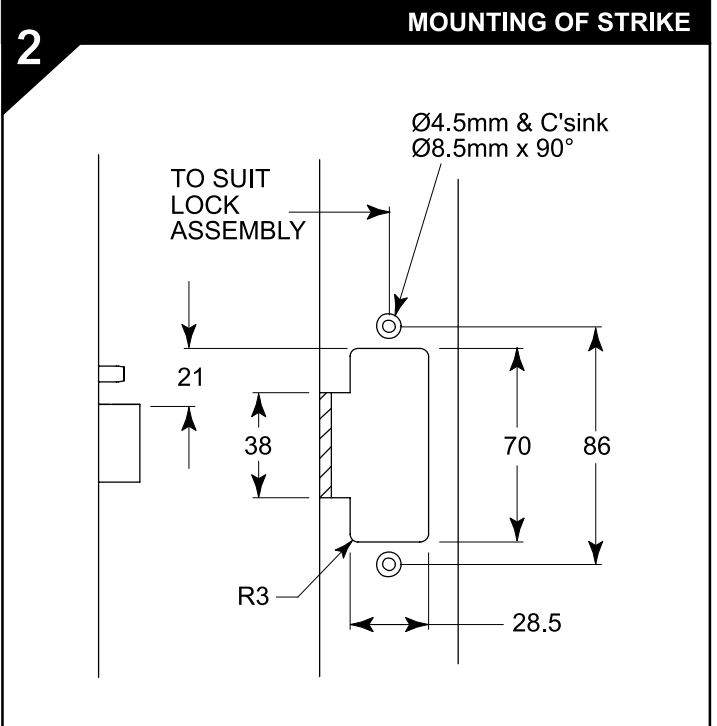

- Prepare door jamb cutout as above.
- Fit strike to strike box and then fit to frame and secure with 2 screws.



3570 SERIES MORTICE LOCK INSTALLATION INSTRUCTIONS FOR METAL DOORS

Part No. 3570-121
30621-0710

1 PREPARE DOOR FOR LOCK

- Establish height at which lockset will be on door.
- Cut COVER PLATE window as per dimensions above.
- Using instructions and template from main instruction, drill the holes for the cylinder, furniture etc.

2 INSTALL MOUNT BRACKETS

No.8 x 16mm Self-tapping screw (supplied in bracket kit)

Metal Door Frame mount bracket

- Secure Metal Door Frame mount brackets as shown above with two of the No.8 x 16mm screws provided in the bracket kit.

3 INSTALL MORTICE LOCK

No.8 x 16mm Self-tapping screw (supplied in bracket kit)

- Insert mortice lock into cavity and secure to the Metal Door Frame mount brackets with the remaining No.8 x 16mm screws supplied in bracket kit.
- Finish assembling mortice lock as per main instructions.

4 MOUNTING STRIKE

Ø4.5mm & C'sink Ø8.5mm x 90°

TO SUIT LOCK ASSEMBLY

21

38

70

86

R3

28.5

- Prepare door jamb cutout as above.
- Fit strike to strike box and then fit to frame and secure with 2 screws.

3571/3573 MORTICE LOCK MOUNTING INSTRUCTIONS

USE THIS INSTRUCTION IN CONJUNCTION WITH THE RELEVANT FURNITURE MOUNTING INSTRUCTION.

Important : Before drilling door, ensure correct hand is being installed.

ESCAPE FUNCTION: External cylinder locks and unlocks bolt, Internal lever allows escape only.

Part No. 3571-121
35021-0809

RIGHT - HAND DOOR		LEFT - HAND DOOR		SLIDING DOOR	
OUTSIDE DOOR OPENING IN	OUTSIDE DOOR OPENING OUT	OUTSIDE DOOR OPENING IN	OUTSIDE DOOR OPENING OUT	OUTSIDE RIGHT HAND	OUTSIDE LEFT HAND

1 MORTICE DOOR

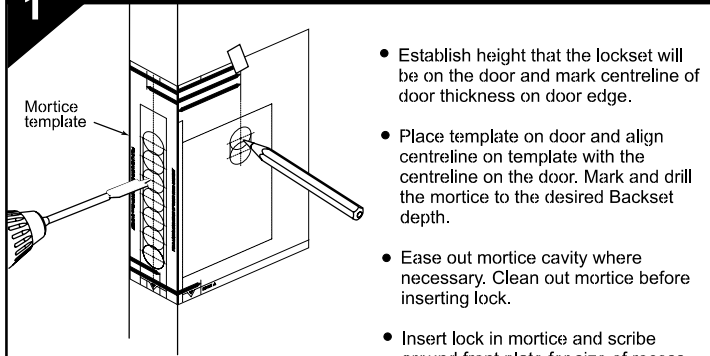

- Establish height that the lockset will be on the door and mark centreline of door thickness on door edge.
- Place template on door and align centreline on template with the centreline on the door. Mark and drill the mortise to the desired Backset depth.
- Ease out mortise cavity where necessary. Clean out mortise before inserting lock.
- Insert lock in mortise and scribe around front plate for size of recess.

- Remove lock from mortise and chisel recess 4mm deep to receive front and cover plate. Cover plate must be flush with edge of door.
- Ensure lock is removed from mortise cavity. Fold template to desired backset. Align EDGE A with bottom of cover plate recess.
- Establish holes required to suit lock function, mark hole centres accurately, drill and clean holes.
- IMPORTANT**
TO PREVENT DAMAGE TO THE DOOR FACE FROM DRILL BREAKTHROUGH, MARK BOTH SIDES OF THE DOOR AND DRILL HOLES HALFWAY THROUGH EACH SIDE.

2 ASSEMBLE MORTICE LOCK

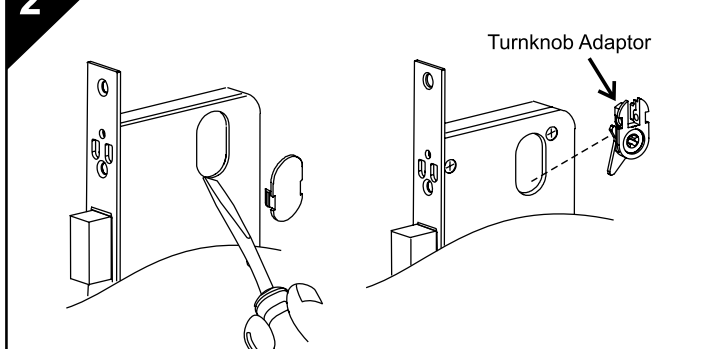

- Using a small flat screwdriver, lever out cylinder hole plugs if present.
- With the bolt extended, insert the Turnknob adaptor into the interior side of the mortise lock with the adaptor lever pointing forward.

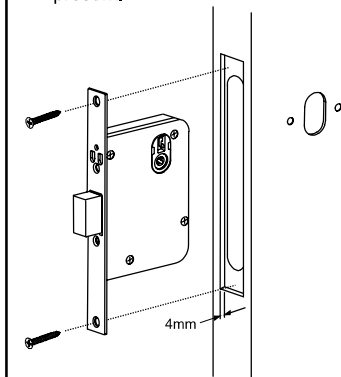

- Ensure bolt is fully extended and assemble into mortise. Fix with two screws provided.

3 ASSEMBLE ESCAPE TURN LEVER

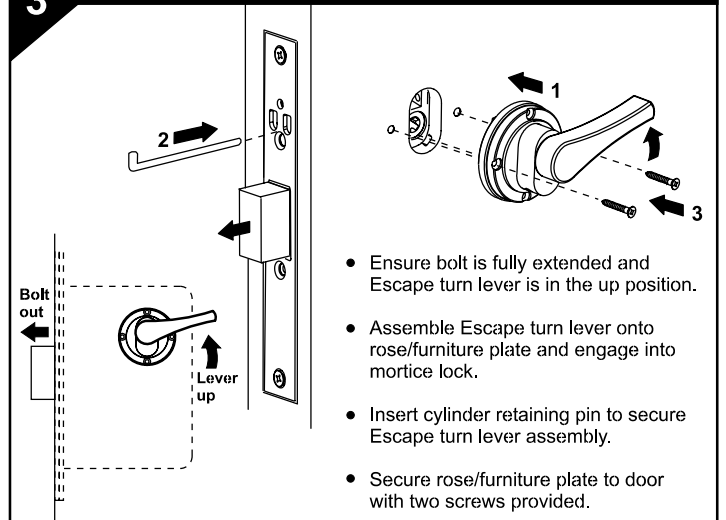

- Ensure bolt is fully extended and Escape turn lever is in the up position.
- Assemble Escape turn lever onto rose/furniture plate and engage into mortise lock.
- Insert cylinder retaining pin to secure Escape turn lever assembly.
- Secure rose/furniture plate to door with two screws provided.

4 ASSEMBLE TRIM

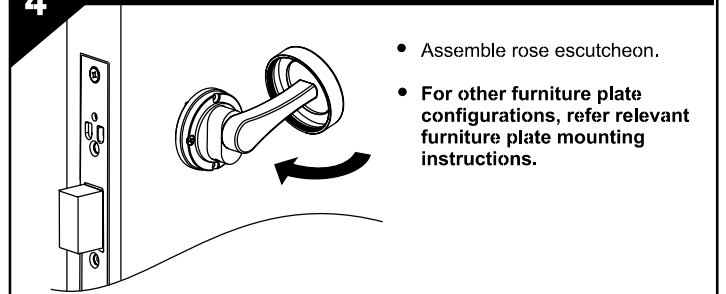

- Assemble rose escutcheon.
- For other furniture plate configurations, refer relevant furniture plate mounting instructions.

TURKNOB ASSEMBLY

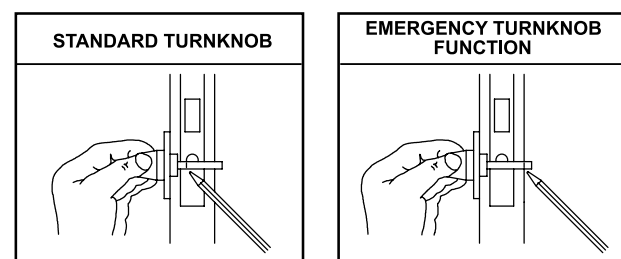

- Mark and cut connecting bar as shown.
- Turn knob to be in the vertical position when UNLOCKED.

5 ASSEMBLE CYLINDER

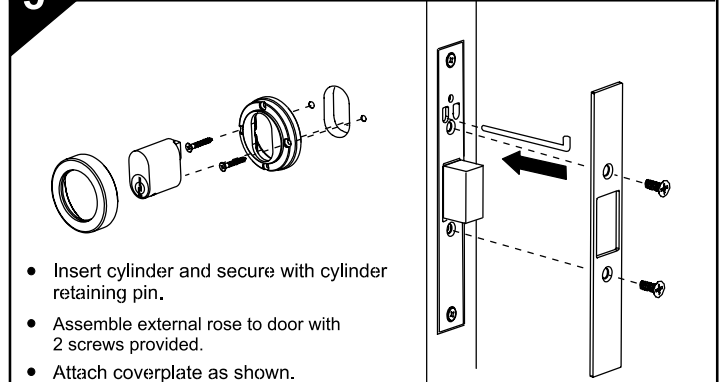

- Insert cylinder and secure with cylinder retaining pin.
- Assemble external rose to door with 2 screws provided.
- Attach coverplate as shown.
- Assemble rose escutcheon.

6

ASSEMBLE STRIKE - 3571

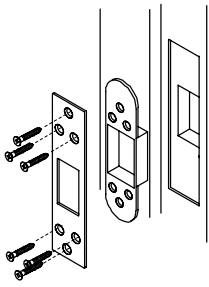

- Mark out door frame for strike.
- Mortice door frame for strike box and strike. Bolt recess to be 20mm Deep in door frame.
- Screw strike and strike box to the door frame with the screws provided.

ASSEMBLE STRIKE - 3573 Sliding Door Function

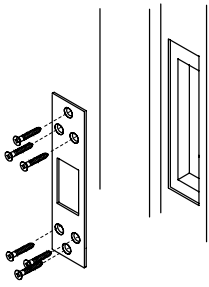

- Mark out door frame for strike.
- Mortice door frame for strike and mortice a 20mm Deep recess for the bolt head to clear the locking lugs.
- Screw strike and strike box to the door frame with the screws provided.

FITTING TURNKNOBS FOR PT SERIES PRIVACY DEADBOLTS

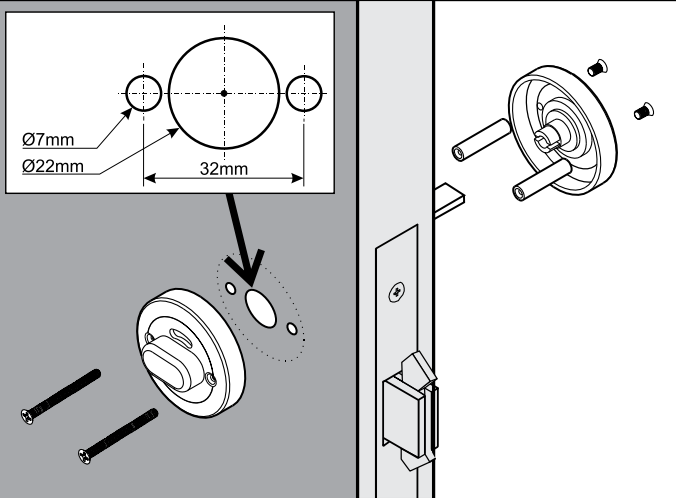



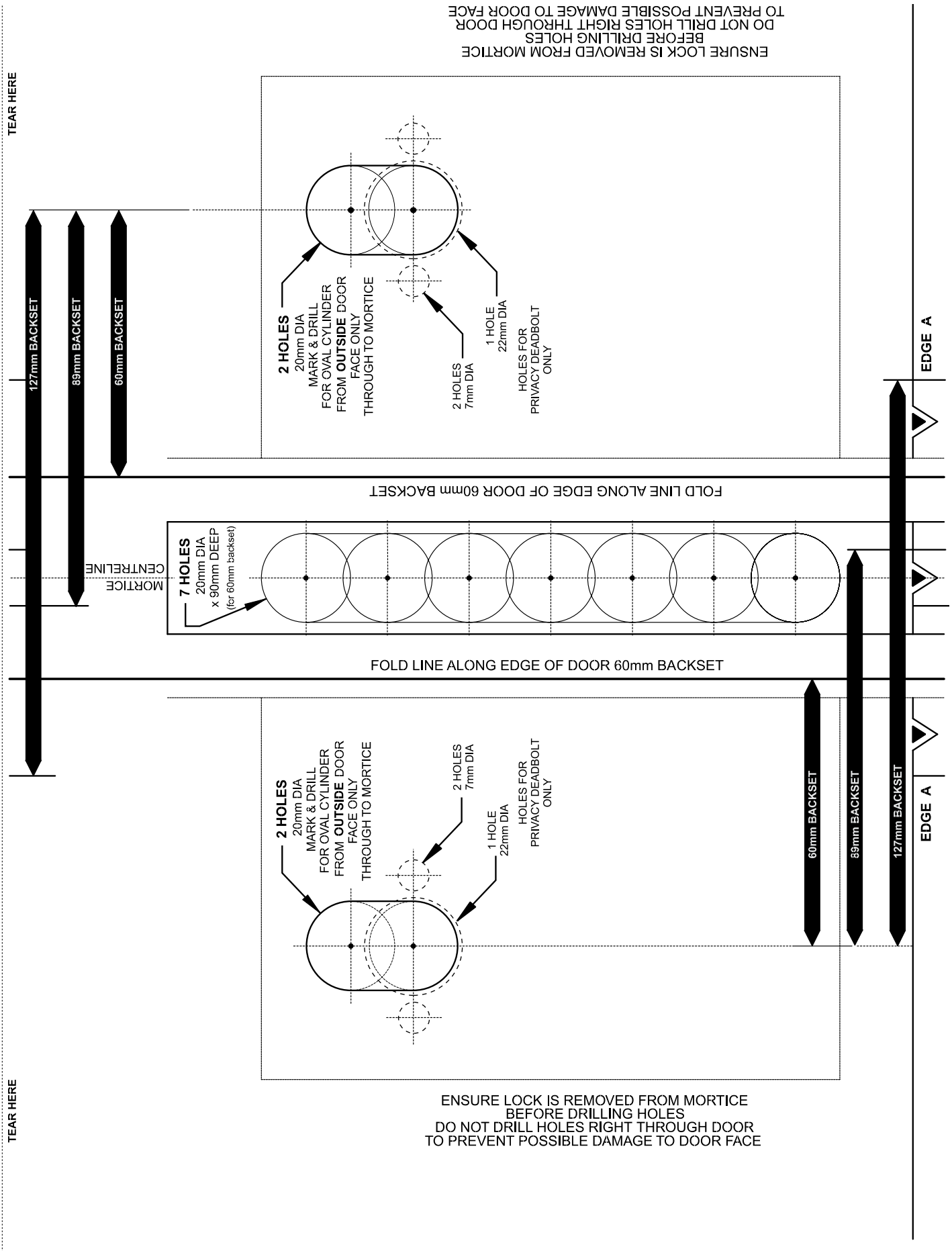

3571/3573 MORTICE LOCK MOUNTING INSTRUCTIONS



3577 SERIES DUAL ENTRY MORTICE LOCK MOUNTING INSTRUCTIONS

P/No. 3577-5121_30621 1009

HAND OF DOOR ACCORDING TO ENGLISH PRACTICE

RIGHT - HAND DOOR		LEFT - HAND DOOR	
			
OUTSIDE DOOR OPENING IN	OUTSIDE DOOR OPENING OUT	OUTSIDE DOOR OPENING IN	OUTSIDE DOOR OPENING OUT

- Determine hand of lock required from hand of door chart above.
- All Lockwood 3570 Series Mortice Locks with Dual entry cylinders are mounted in accordance with these instructions. Disregard instructions referring to the features not required. Important : Before drilling door, ensure correct hand is being installed. NOTE: CASE DOES NOT need to be opened, to change HAND or FUNCTION of LOCK.

HANDING OF LOCK

- Determine hand of lock required from above hand of door chart.
- Rotate bolt head to suit latching direction.

1 PREPARE DOOR FOR LOCK

1. Establish height that lockset will be on door and mark centreline of door thickness on door edge.
2. Place template on door and align centreline on template with centreline on door. Mark and drill mortice.
3. Ease out mortice cavity where necessary.
4. Insert lock in mortice and scribe around front plate for size of recess. Remove lock from mortice and chisel recess 4mm deep to receive front and cover plate. Cover plate must be flush with edge of door.
5. ENSURE lock is removed from MORTICE cavity. Fold template and align EDGE A with bottom of coverplate recess. Establish holes required to suit lock furniture, mark hole centres LOCK accurately and drill holes.

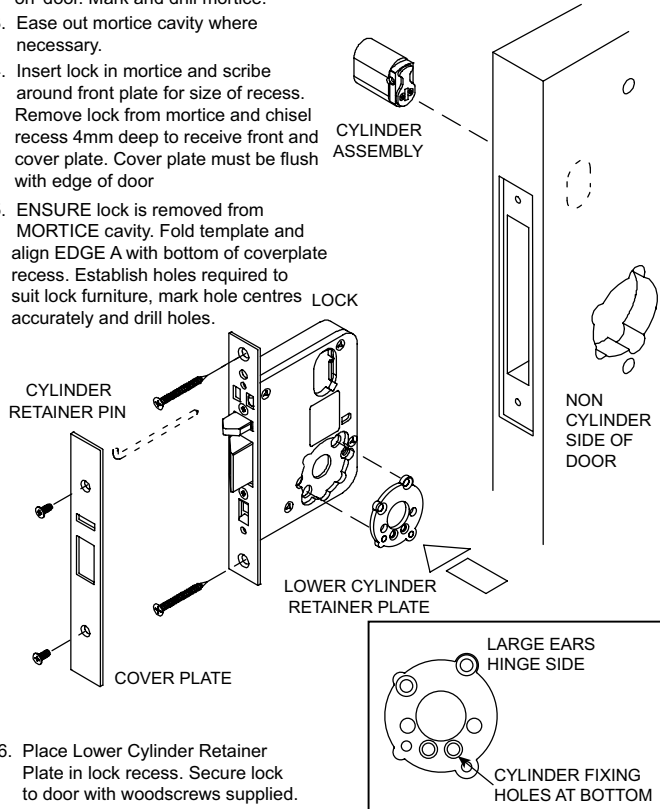

6. Place Lower Cylinder Retainer Plate in lock recess. Secure lock to door with woodscrews supplied.

2 MOUNTING OF UPPER CYLINDER

1. Using a small flat screwdriver, lever out Cylinder Hole Plug where fitted and insert Cylinder.
2. Secure Cylinder with Retainer Pin, ensuring pin is flush with front plate.
3. Install Cover plate and secure with 2 M4 screws to lock body.

3 MOUNTING OF LOWER CYLINDER

1. Assemble lower cylinder to mounting plate with 2 screws.
2. Install Lower Cylinder Assembly to lock and secure with screws supplied.

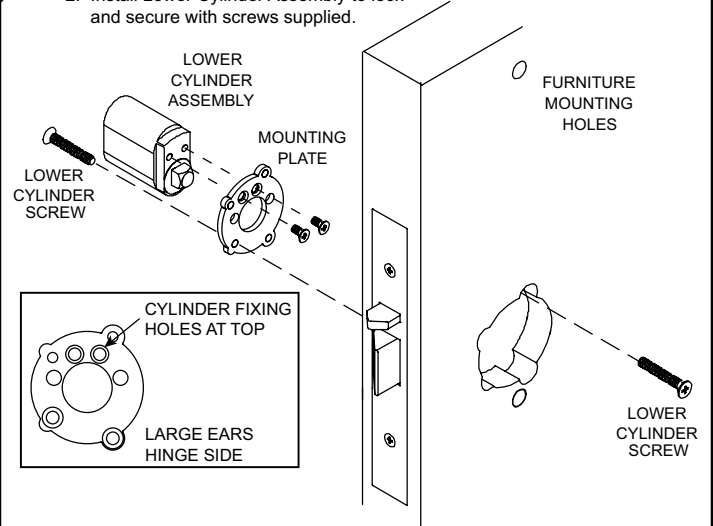

4 INSTALL FURNITURE

1. Attach door furniture with screws provided.
- NOTE : - For brass 1000 series, cut screws to length (Door thickness + 13mm)
- For aluminium 2000 series, screws supplied suit 35 - 45mm door thickness.
For doors 45 - 55mm order screws 2000-208

5 MOUNTING STRIKE

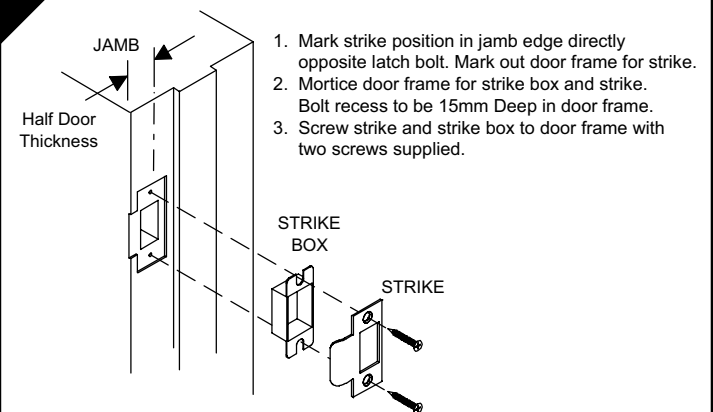

1. Mark strike position in jamb edge directly opposite latch bolt. Mark out door frame for strike.
2. Mortice door frame for strike box and strike. Bolt recess to be 15mm Deep in door frame.
3. Screw strike and strike box to door frame with two screws supplied.

3577 SERIES DUAL ENTRY MORTICE LOCK

MOUNTING INSTRUCTIONS

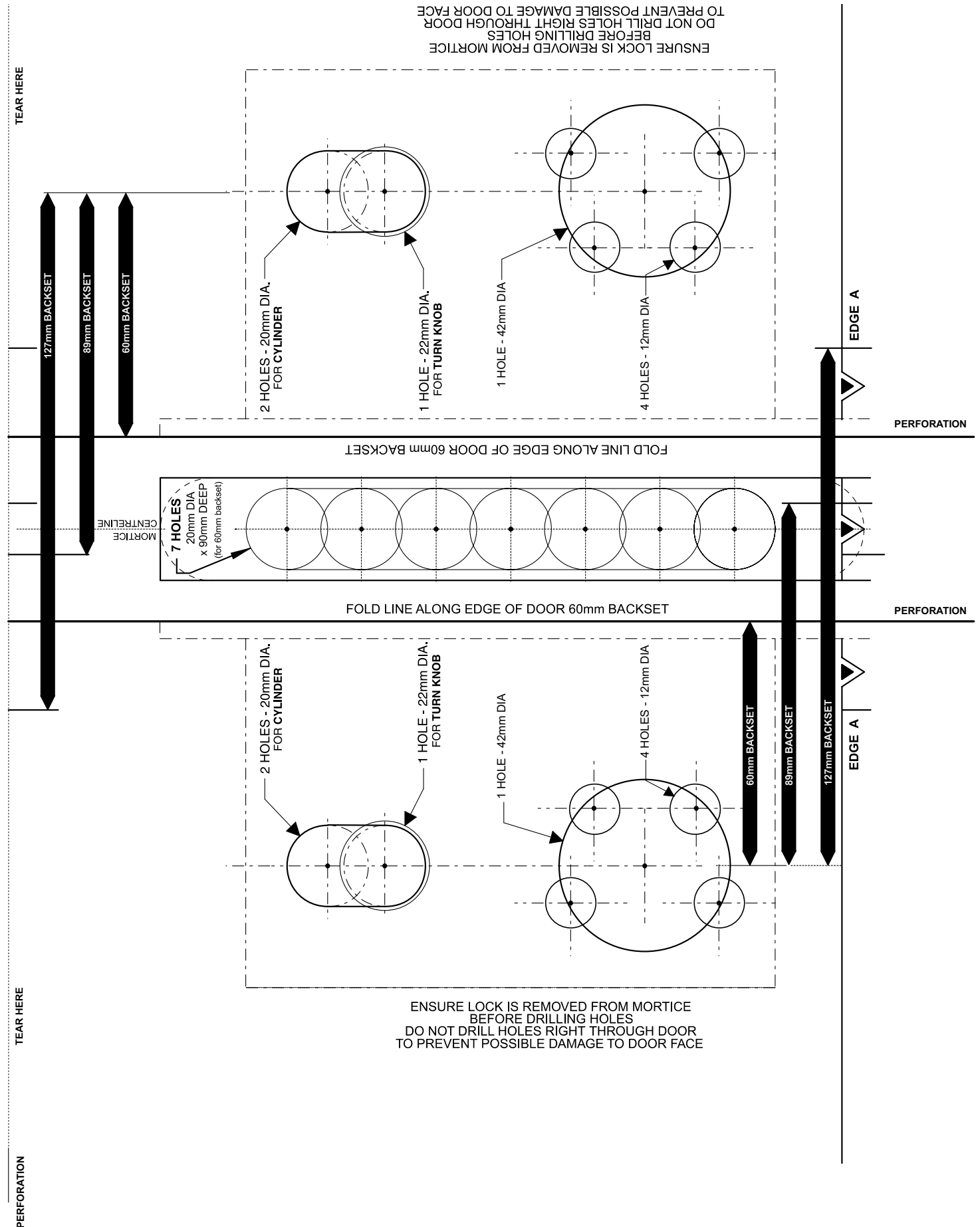

3578 SERIES MORTICE LOCK MOUNTING INSTRUCTIONS

P/No. 3578-5121_30621_0506

HAND OF DOOR ACCORDING TO ENGLISH PRACTICE

RIGHT - HAND DOOR		LEFT - HAND DOOR	
OUTSIDE DOOR OPENING IN	OUTSIDE DOOR OPENING OUT	OUTSIDE DOOR OPENING IN	OUTSIDE DOOR OPENING OUT

- Determine hand of lock required from hand of door chart above.
- All Lockwood 3578 Series Mortice Locks are mounted in accordance with these instructions. Locks may or may not have cylinders, lever handles, turn knob or emergency button. Disregard instructions referring to the features not required.
- Important : Before drilling door, ensure correct hand is being installed.
- NOTE: CASE DOES NOT need to be opened, to change HAND or FUNCTION of LOCK.

HANDING OF LOCK

- Determine hand of lock required from above hand of door chart.
- Rotate bolt head to suit latching direction.

1 SETTING LOCK STATUS

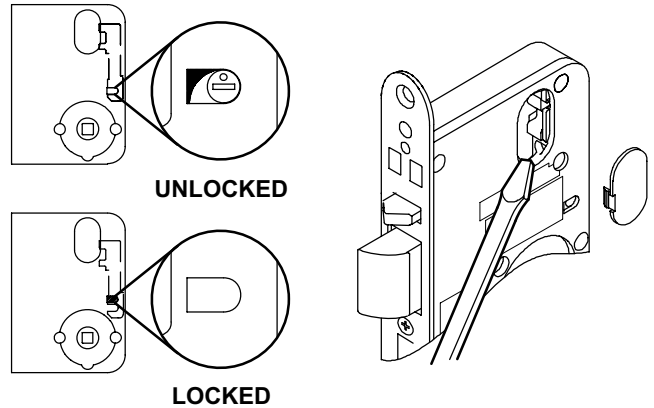

- Ensure lock is in UNLOCKED position.
- To UNLOCK (if required), using a small screwdriver, lever out Cylinder Hole Plug where fitted and lift snib using the screwdriver.

2 SETTING LOCK STATUS

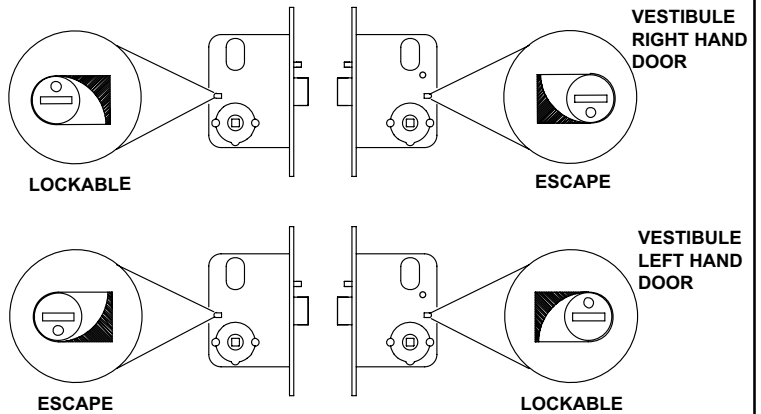
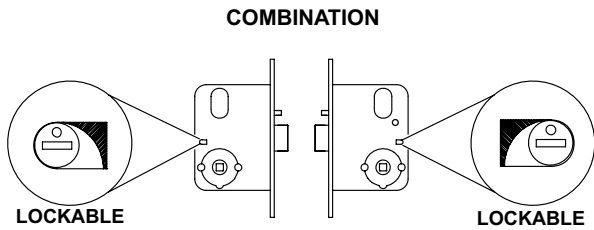

- **SNIB CAM**
Rotation of the Snib Cam hands the lock. Use a small screwdriver to rotate cam if required.
- **Combination locks**
(Both handles can be locked) DOT in the up position.

- **Vestibule Locks**
With single action escape feature. DOT to be DOWN on ESCAPE side and UP on LOCKABLE side.

3 TURN KNOB ADAPTORS

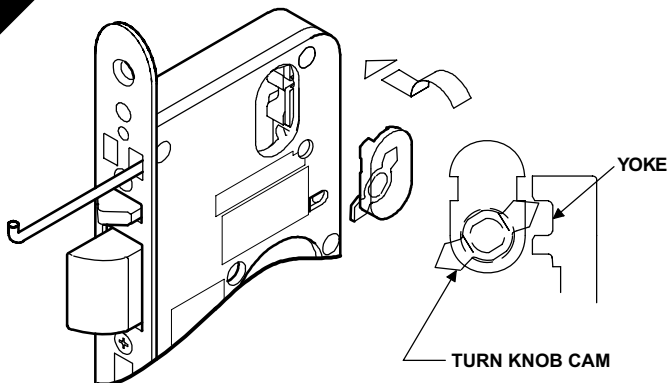

- Establish which side the adaptor is to be located, lever out Cylinder hole plug where fitted.
- **PUT LOCK IN LOCKED POSITION, as shown in Step 1.**
- Insert Adaptor into lock body with TOP of Turn Knob Cam point away from front of lock body. **Ensure Turn Knob Cam is engaged in yoke of snib as shown.**
- Place retainer pin through front plate to retain adaptor to lock. Ensure pin is flush with front plate

4 DOOR PREPARATION

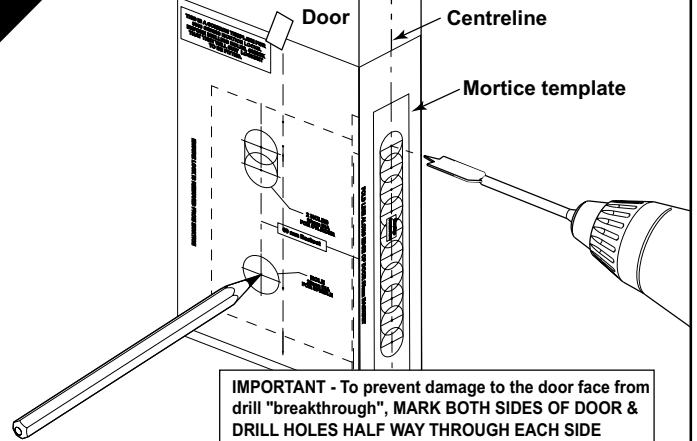

- Establish height that lockset will be mounted on door and mark centreline of door thickness on door edge.
- Place Mortise Template on door and align centreline on template with centreline on door. Secure with sticky tape.
- Mark and drill mortise to suit mortice lock depth (90mm).

3578 SERIES MORTICE LOCK MOUNTING INSTRUCTIONS

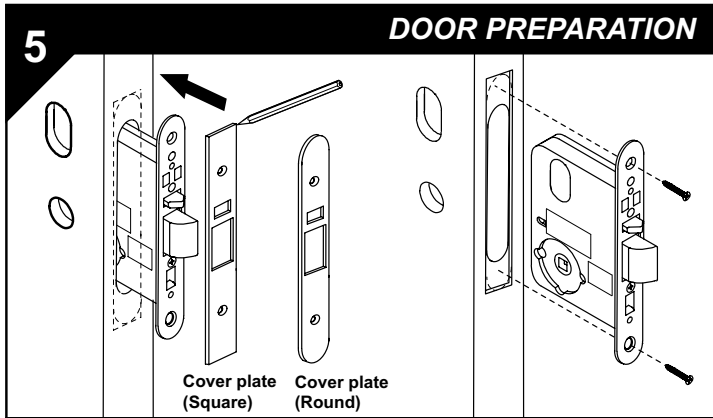

- Ease out mortise cavity where necessary. Clean out mortise before inserting lock.
- Insert lock in mortise with Cover Plate on and scribe around Cover Plate for size of recess, ensuring that no foreign matter finds its way into the lock mechanism.
- Remove lock from mortise and chisel recess 4mm deep to receive both front and cover plate. Cover plate must be flush with edge of door.
- Ensure lock is removed from mortise cavity. Fold template along backset fold line. Align EDGE A with bottom of cover plate recess. Establish holes required to suit lock function, mark hole centres accurately, drill and clean holes.
- Drill furniture holes as required.
- Fasten mortise lock into door using mounting screws provided.

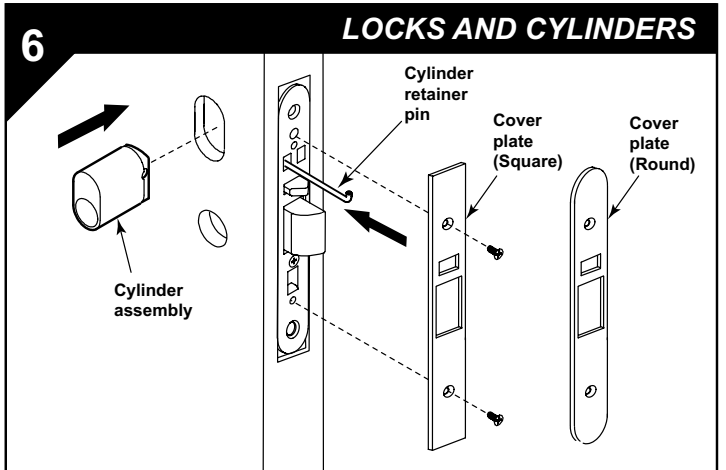

LOCKS WITH CYLINDERS

- Place lock in mortise and insert cylinder.
- Secure cylinder with retainer pin, ensuring pin is flush with front plate.
- Install Cover plate and secure with 2 M4 screws provided to lock body.

LOCKS WITHOUT CYLINDERS

- Install Cover plate and secure with 2 M4 screws provided to lock body.

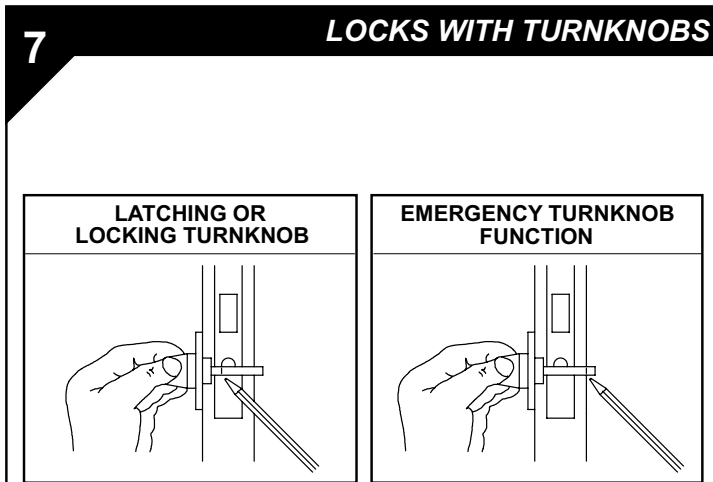

- Mark and cut connecting bar as shown.
- Turn knob to be in the vertical position when UNLOCKED.

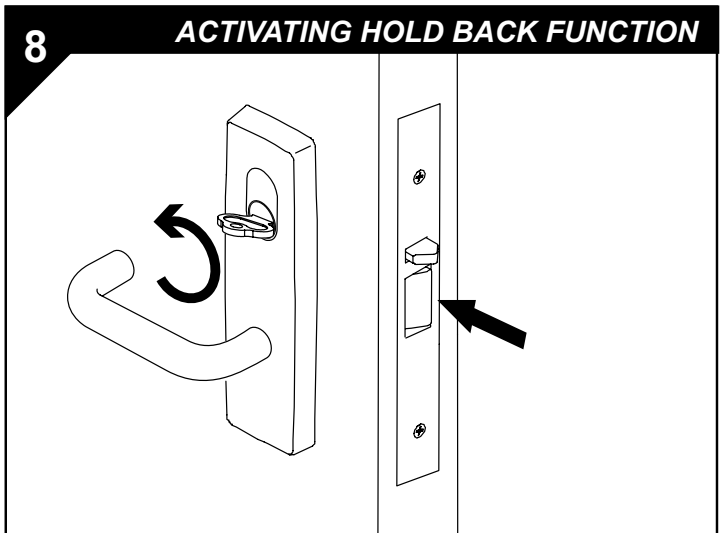

- To activate HOLD BACK function, depress latchbolt with thumb and turn key or turn knob.
- To de-activate HOLD BACK function turn key or turn knob in opposite direction.

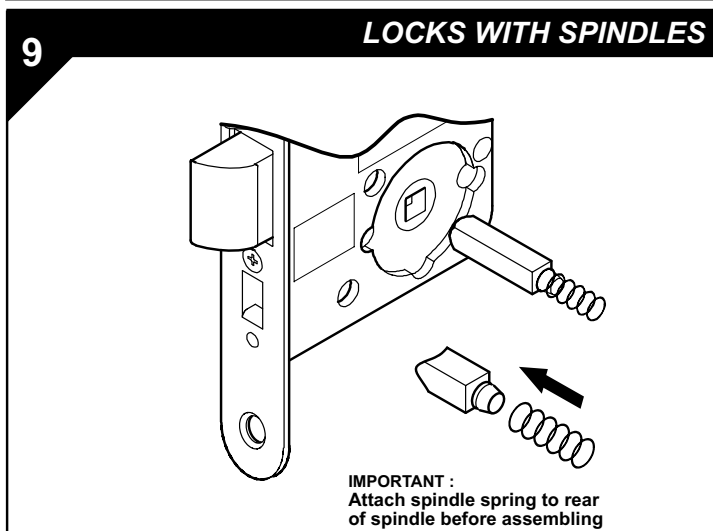

- All locks are supplied with spindles.
- Insert spindle(s) into lock, as required.
- Assemble furniture as required. Ensure furniture is not over-tightened.

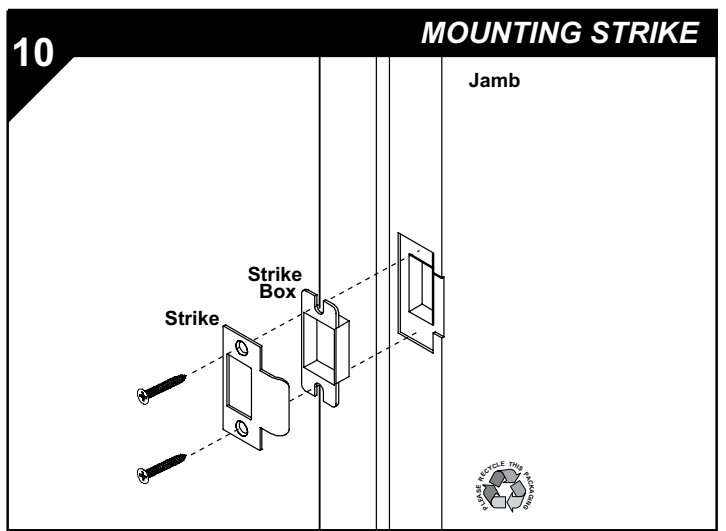

- Mark out door frame for strike.
- Mortise door frame for strike box and strike. Bolt recess to be 15mm deep in door frame.
- Screw strike and strike box to the door frame with two screws supplied with mortise lock.

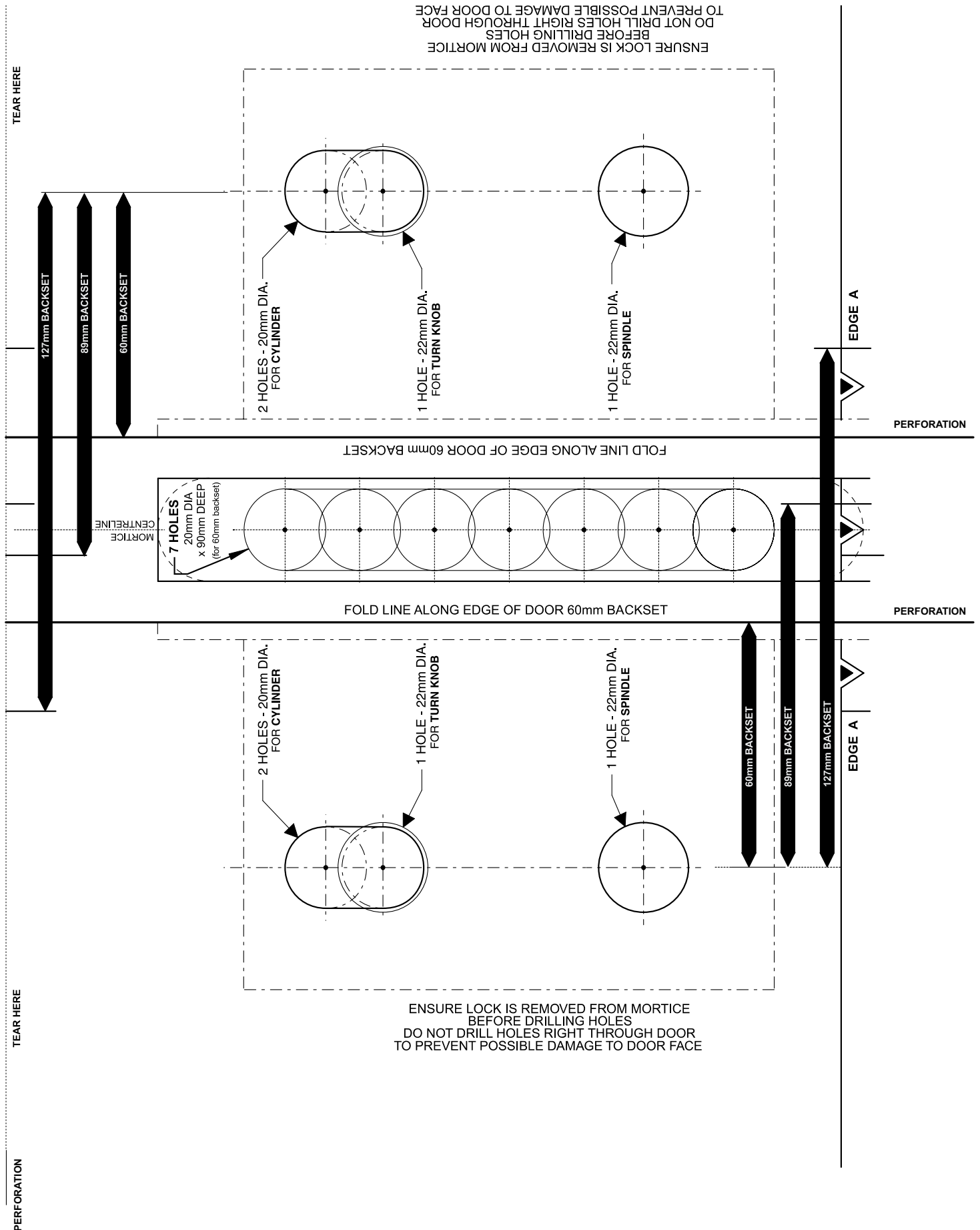

3578 SERIES MORTICE LOCK MOUNTING INSTRUCTIONS



3579 SERIES MORTICE LOCK MOUNTING INSTRUCTIONS

P/No. 3579-5121 30621 0609

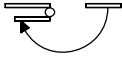
HAND OF DOOR ACCORDING TO ENGLISH PRACTICE

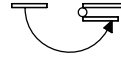
RIGHT - HAND DOOR		LEFT - HAND DOOR	
			
OUTSIDE DOOR OPENING IN	OUTSIDE DOOR OPENING OUT	OUTSIDE DOOR OPENING IN	OUTSIDE DOOR OPENING OUT

- Determine hand of lock required from hand of door chart above.
- All Lockwood 3579 Series Mortice Locks are mounted in accordance with these instructions. Locks may or may not have cylinders, lever handles, turn knob or emergency button. Disregard instructions referring to the features not required.
- Important : Before drilling door, ensure correct hand is being installed.
- NOTE: CASE DOES NOT need to be opened, to change HAND or FUNCTION OF LOCK.

HANDING OF LOCK

- Determine hand of lock required from above hand of door chart.
- Rotate bolt head to suit latching direction.

1 SETTING LOCK STATUS

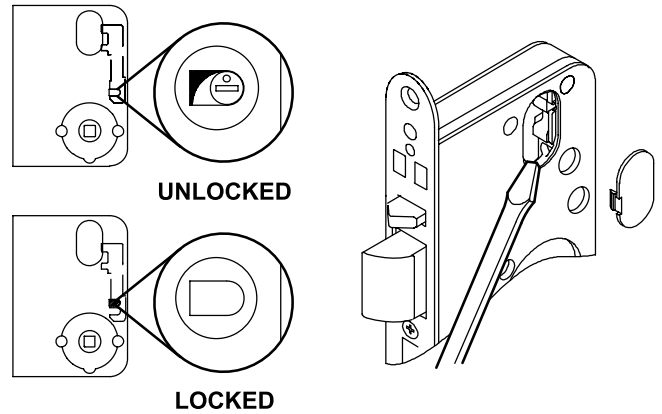

- Ensure lock is in UNLOCKED position.
- To UNLOCK (if required), using a small screwdriver, lever out Cylinder Hole Plug where fitted and lift snib using the screwdriver.

2 SETTING LOCK STATUS

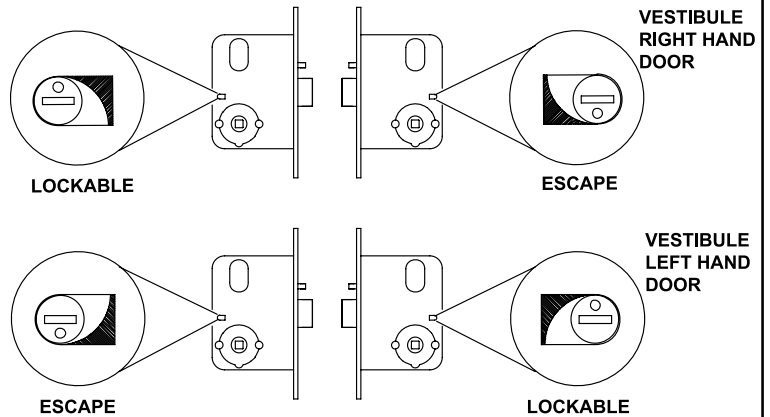
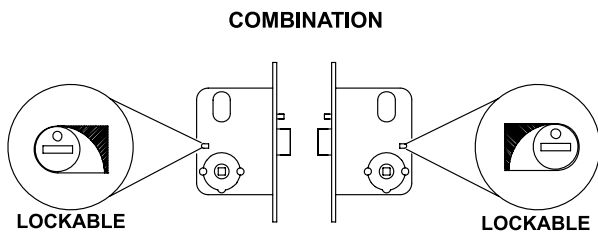

- **SNIB CAM**
Rotation of the Snib Cam hands the lock. Use a small screwdriver to rotate cam if required.
- **Combination locks**
(Both handles can be locked) DOT in the up position.

- **Vestibule Locks**
With single action escape feature. DOT to be DOWN on ESCAPE side and UP on LOCKABLE side.

3 SETTING KICK-OFF FUNCTION

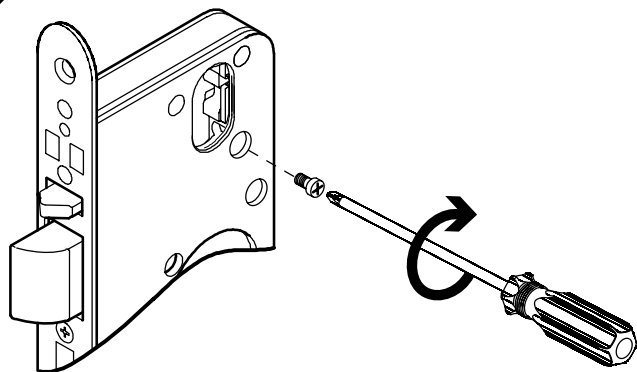

- To de-activate KICK-OFF function, ensure the lock is unlocked, then remove the KICK-OFF screw as shown. Rotate screw in the direction of the arrow as the screw is left hand thread.

4 TURN KNOB ADAPTORS

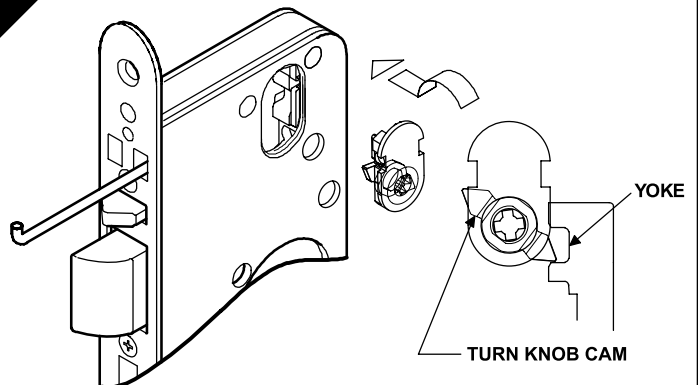

- Establish which side the adaptor is to be located, lever out Cylinder hole plug where fitted.
- **PUT LOCK IN LOCKED POSITION**, as shown in Step 1.
- Insert Adaptor into lock body with TOP of Turn Knob Cam point away from front of lock body. **Ensure Turn Knob Cam is engaged in yoke of snib as shown.**
- Place retainer pin through front plate to retain adaptor to lock. Ensure pin is flush with front plate

3579 SERIES MORTICE LOCK MOUNTING INSTRUCTIONS

5 DOOR PREPARATION

IMPORTANT - To prevent damage to the door face from drill "breakthrough", MARK BOTH SIDES OF DOOR & DRILL HOLES HALF WAY THROUGH EACH SIDE

- Establish height that lockset will be mounted on door and mark centreline of door thickness on door edge.
- Place Mortise Template on door and align centreline on template with centreline on door. Secure with sticky tape.
- Mark and drill mortise to suit mortise lock depth (90mm).

6 DOOR PREPARATION

- Ease out mortise cavity where necessary. Clean out mortise before inserting lock.
- Insert lock in mortise with Cover Plate on and scribe around Cover Plate for size of recess, ensuring that no foreign matter finds its way into the lock mechanism.
- Remove lock from mortise and chisel recess 4mm deep to receive both front and cover plate. Cover plate must be flush with edge of door.
- Ensure lock is removed from mortise cavity. Fold template along backset fold line. Align EDGE A with bottom of cover plate recess. Establish holes required to suit lock function, mark hole centres accurately, drill and clean holes.
- Drill furniture holes as required.
- Fasten mortise lock into door using mounting screws provided.

7 LOCKS AND CYLINDERS

LOCKS WITH CYLINDERS

- Place lock in mortise and insert cylinder.
- Secure cylinder with retainer pin, ensuring pin is flush with front plate.
- Install Cover plate and secure with 2 M4 screws provided to lock body.

LOCKS WITHOUT CYLINDERS

- Install Cover plate and secure with 2 M4 screws provided to lock body.

8 LOCKS WITH TURNKNOBS

LATCHING OR LOCKING TURNKNOB

EMERGENCY TURNKNOB FUNCTION

- Mark and cut connecting bar as shown.
- Turn knob to be in the vertical position when UNLOCKED.

9 LOCKS WITH SPINDLES

IMPORTANT: Attach spindle spring to rear of spindle before assembling

- All locks are supplied with spindles.
- Insert spindle(s) into lock, as required.
- Assemble furniture as required. Ensure furniture is not over-tightened.

10 MOUNTING STRIKE

- Mark out door frame for strike.
- Mortise door frame for strike box and strike. Bolt recess to be 15mm deep in door frame.
- Screw strike and strike box to the door frame with two screws supplied with mortise lock.

3579 SERIES MORTICE LOCK MOUNTING INSTRUCTIONS

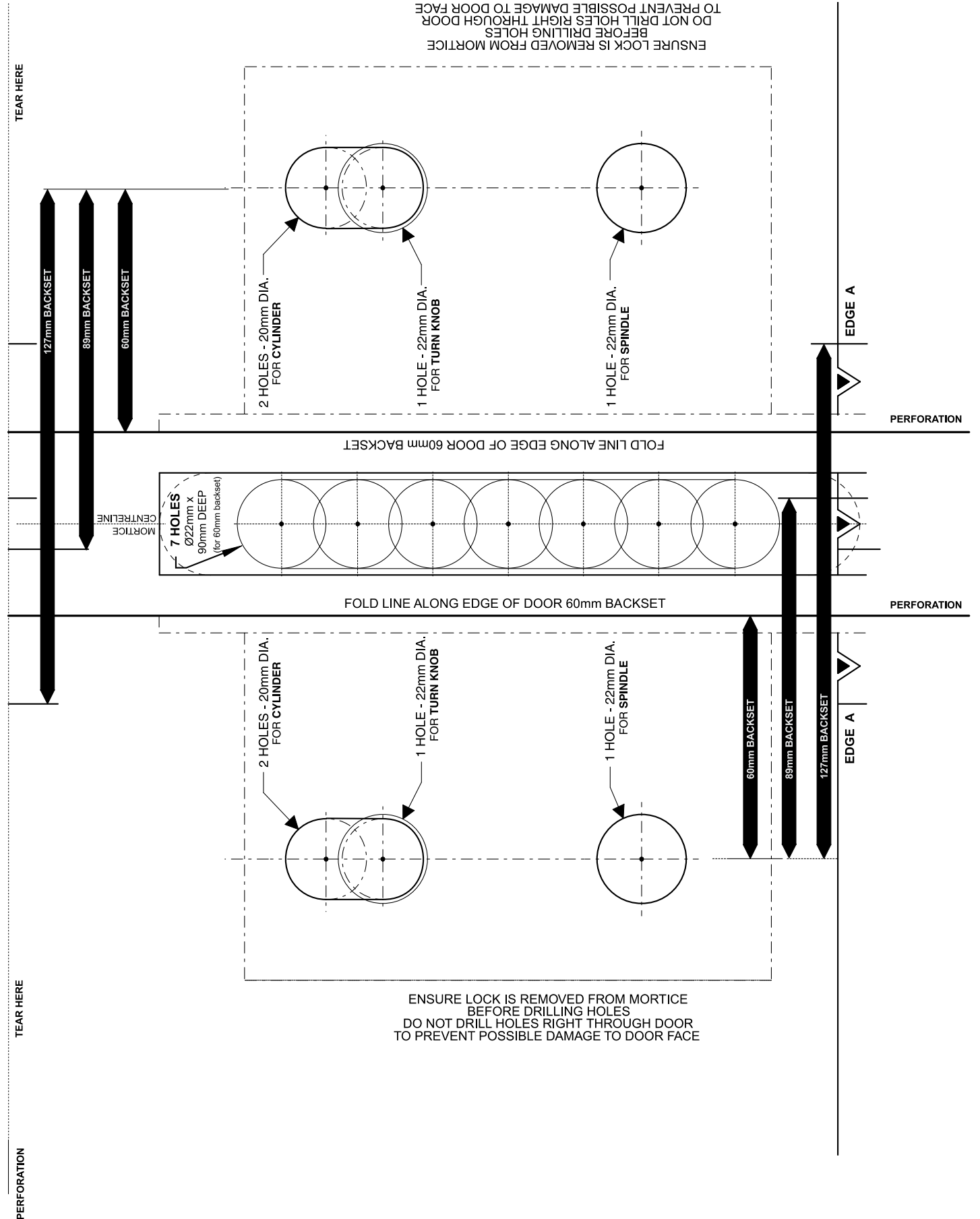

3570 SERIES REBATE MORTICE LOCKS

MOUNTING INSTRUCTIONS

P/No. 3870-5221
30621 0312

All Lockwood 3P70 Series Rebate Mortice Lock Kits are to be mounted in accordance with this instruction and in conjunction with the standard instructions supplied with the LOCK.

MORTICE INSTRUCTION

1. Place LOCK instruction template on door. Mark and drill mortice to desired BACKSET depth.
2. Ease out mortice where necessary.
3. Place lock through SPACER and insert lock in mortice, scribe around spacer for size of recess. Remove lock from mortice and chisel out recess to receive spacer. Faceplate must be flush with protruding edge of door.

MOUNTING STRIKE

1. Mark out door frame for strike.
2. Mortice door frame for strike.
N.B. Strike to be flush with face of frame. Bolt recess to be 15mm deep in door frame.
3. Screw Strike to door frame with woodscrews provided.

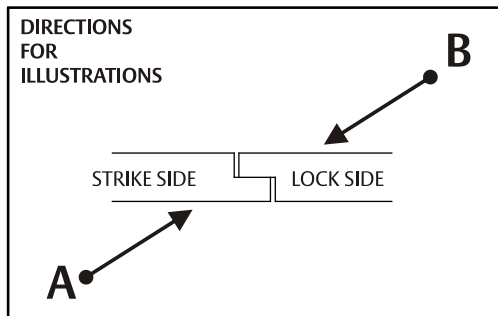

Various Strikes for Rebate Kits

LATCHING REBATE 3P72-RK32	LATCHING REBATE 3P72-RK46	LATCHING REBATE 3571-2902
32mm Lip Strike	46mm Lip Strike	Lipless Strike

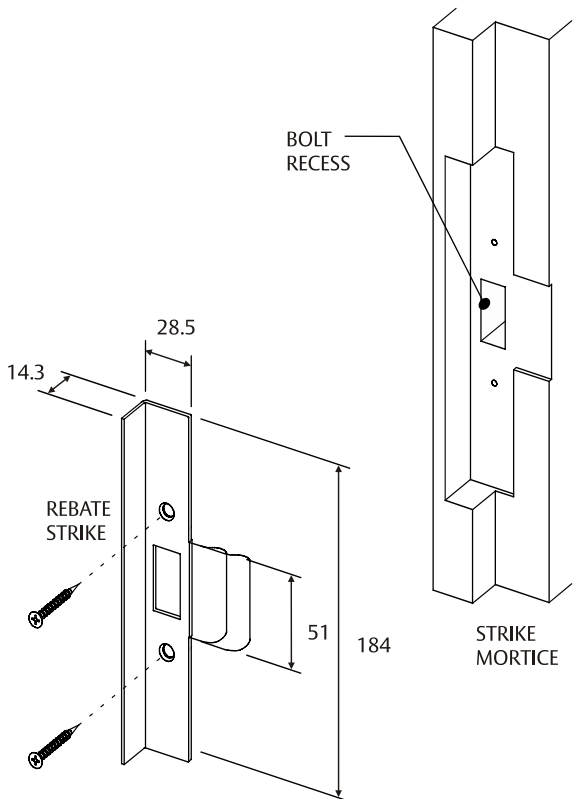

LOCK MORTICE VIEWED IN DIRECTION OF ARROW 'B'

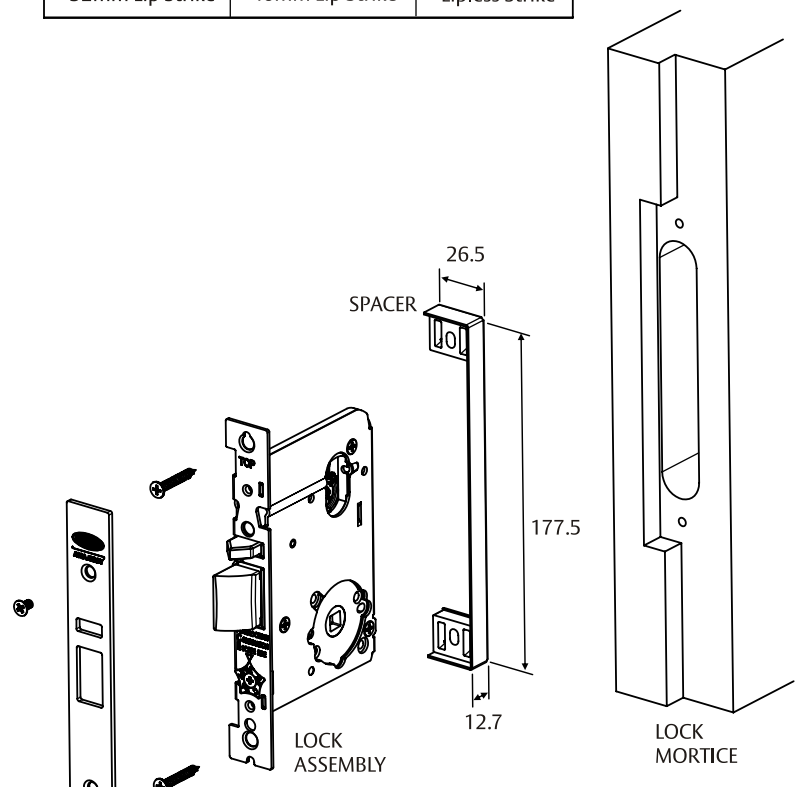

LOCK MORTICE VIEWED IN DIRECTION OF ARROW 'A'

DEADLOCK ASSEMBLIES NOT ILLUSTRATED



ASSA ABLOY

Lockwood is the leading brand in the Australian locking industry. With an established reputation for high quality products, this iconic brand provides a wide range of locking solutions to residential housing, commercial building and industrial application markets. Lockwood is supported by an extensive distribution and after-sales support network. Our customers include retailers, architects, trade and industrial personnel, locksmiths and security dealers.

ASSA ABLOY is the global leader in door opening solutions, dedicated to satisfying end-user needs for security, safety and convenience.

ASSA ABLOY is represented in all major regions, in both mature and emerging markets, with leading positions in Australia, Europe and North America.

As the world's leading lock group, ASSA ABLOY offers a more complete product range of door opening solutions than any other company in the market.

ASSA ABLOY Australia Pty Ltd
235 Huntingdale Road
Oakleigh, Victoria, 3166
Australia

1300 LOCK UP (1300 562 587)
lockweb.com.au

ASSA ABLOY New Zealand Ltd
6 Armstrong Road
Albany, North Shore City, 0632
New Zealand

info.nz@assaabloy.com
Telephone +64 9415 7111
assaabloy.co.nz

* Whilst every effort has been made to ensure that the information contained in this manual is accurate at the time of publication, ASSA ABLOY Australia Pty Limited ("ASSA ABLOY") recommends that you consult ASSA ABLOY or its agents prior to placing an order to ascertain current information on specific products, as ASSA ABLOY reserves the right to make changes without notice. ASSA ABLOY will not be liable for any injury, loss or damage whatsoever, arising from any errors or omissions in the information contained in the manual or arising from the use or application of the information contained herein.

